

OPERATING MANUAL

KOMPAKTOMAT

K500PS / K600PS

K700PS / K800PS

K1000PS

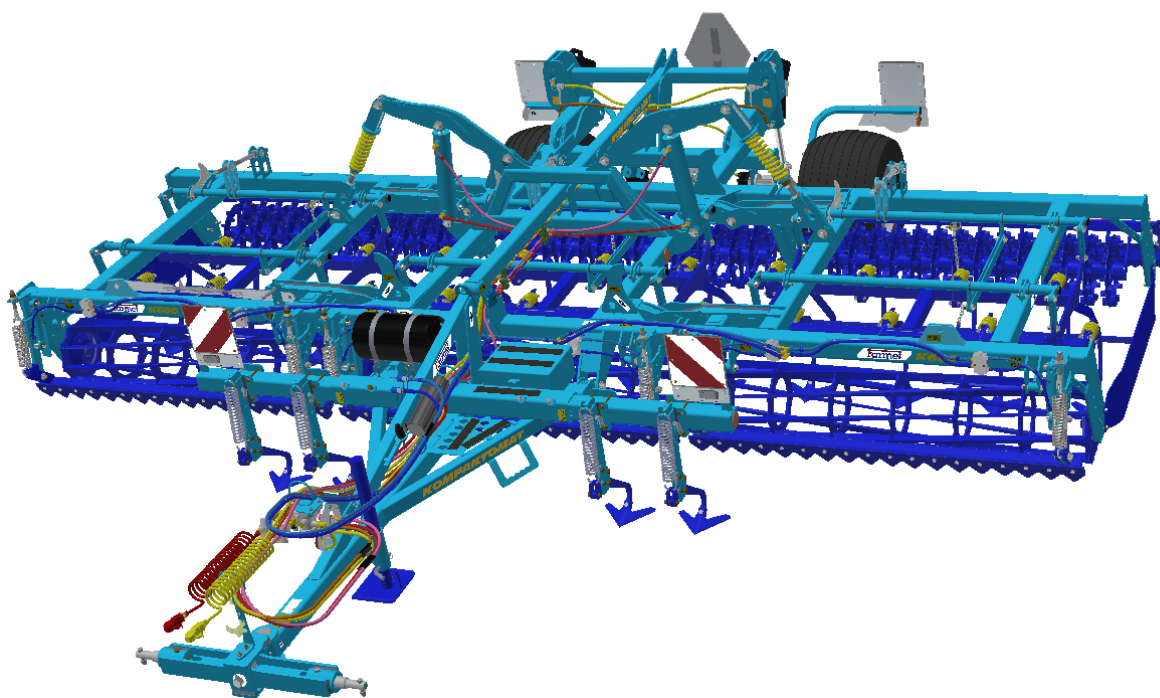

Edition: 5 | effective from: 1. 8. 2023



Dear customer,

Semi-carried machines **KOMPAKTOMAT** are quality products of Farmet a.s. Česká Skalice.

You can fully utilise the advantages of your machine after thoroughly studying the operating manual.

The serial number of the machine is punched on the production label and written in the operating manual (see MACHINE SPECIFICATION). This machine serial number must be stated whenever ordering spare parts for possible repairs. The production label is located on the middle frame near the tow bar.

Use only original spare parts for these machines according to the **Spare parts catalogue** officially issued by the manufacturer, Farmet a.s. Ceska Skalice.

POSSIBILITIES OF USE OF YOUR MACHINE

KOMPAKTOMAT je is intended for presowing preparation of soil as a subsequent operation after ploughing or stubble breaking with incorporated plant residues.

MACHINE SPECIFICATION:

TYPE OF MACHINE KOMPAKTOMAT

SERIAL NUMBER OF MACHINE

USED EQUIPMENT:

.....

.....

.....

.....

.....

K500PS – K800PS

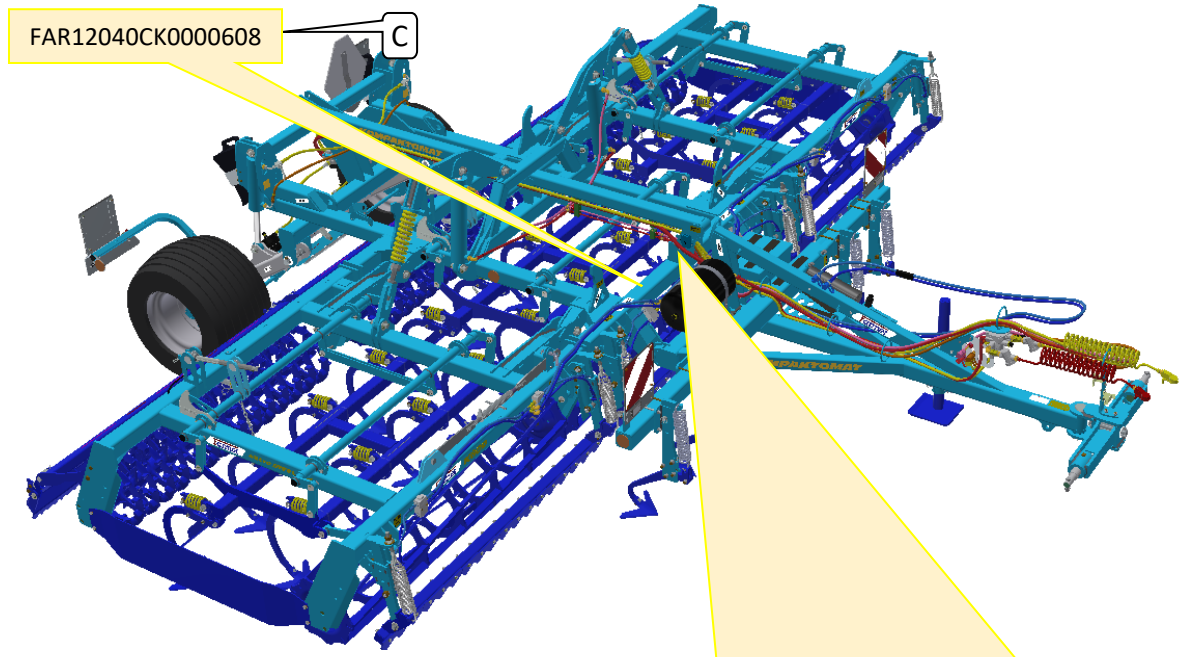

Markings on data plate

ITEM	MARKING
A	Vehicle category according to R167/2013
B	Approval number
C	Seventeen-digit serial number (VIN)
D	Technically permissible maximum laden mass of the vehicle
E	Maximum vertical load on the coupling point
F	Permissible load – axle 1
G	Permissible load – axle 2
H	Permissible load – axle 3
I	Technically permissible towable mass for each chassis/braking configuration for R or S category vehicle
1	Commercial name, general description and purpose
2	Total weight
3	Year of production

K1000PS

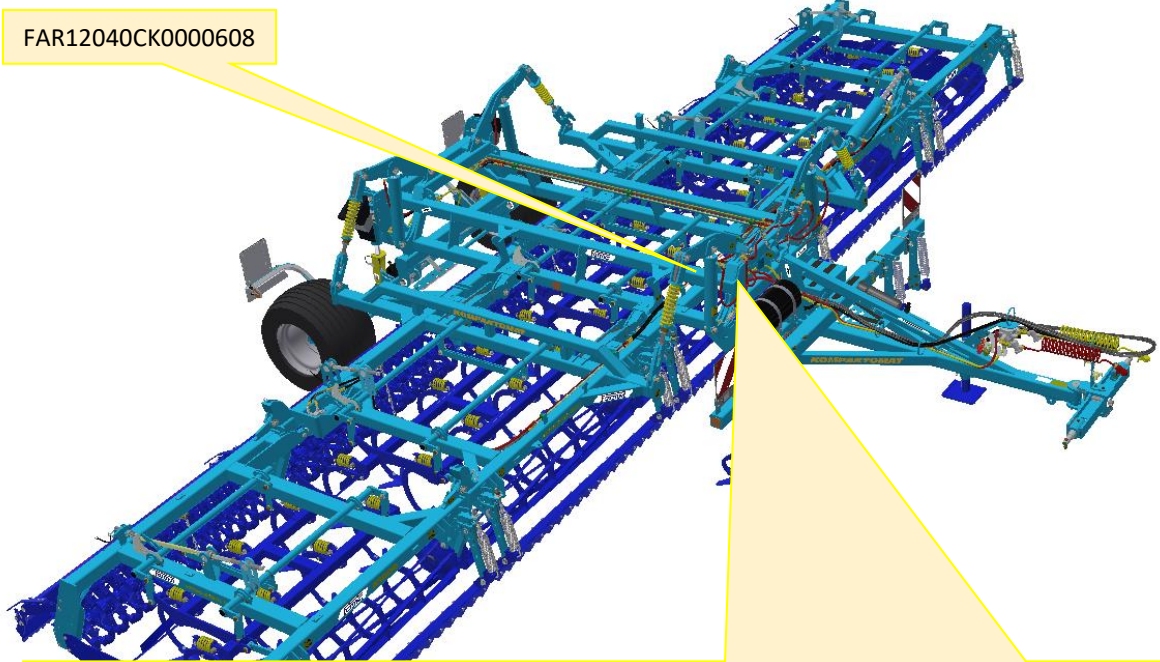

Markings on data plate

ITEM	MARKING
A	Vehicle category according to R167/2013
B	Approval number
C	Seventeen-digit serial number (VIN)
D	Technically permissible maximum laden mass of the vehicle
E	Maximum vertical load on the coupling point
F	Permissible load – axle 1
G	Permissible load – axle 2
H	Permissible load – axle 3
I	Technically permissible towable mass for each chassis/braking configuration for R or S category vehicle
1	Commercial name, general description and purpose
2	Total weight
3	Year of production

AXLE IDENTIFICATION

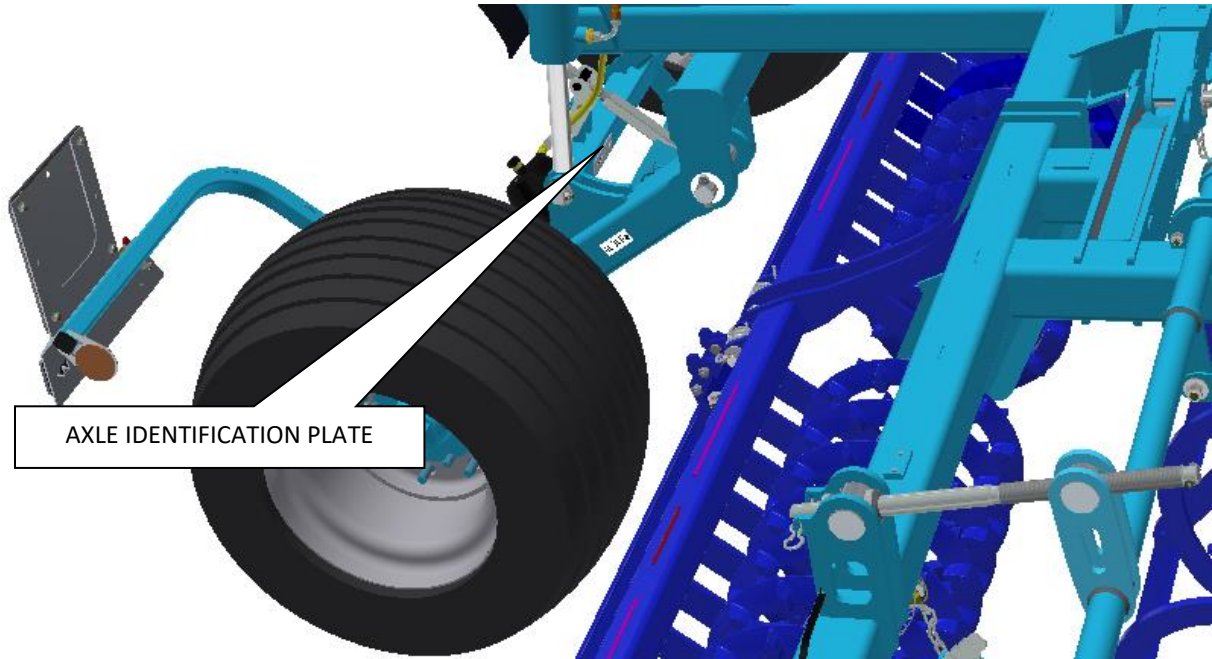

AXLE IDENTIFICATION PLATE

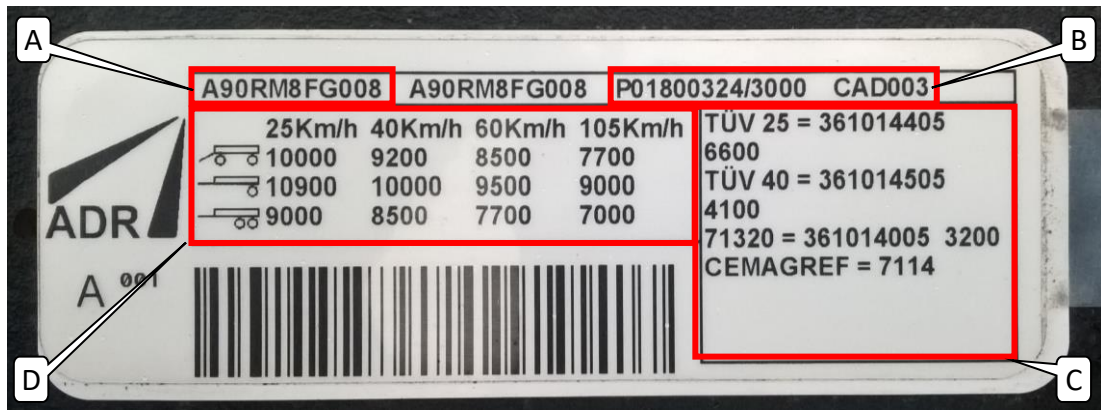

The axle identification plate can be read as follows:

ITEM	MARKING
A	Axle identification code
B	Order identification code
C	Approval report identification code
D	Maximum axle capacity data referred to the application and speed

CONTENTS

BASIC DESCRIPTION OF THE KOMPAKTOMAT MACHINE.....	7
Machine limit parameters.....	10
Safety statement.....	10
A. GENERAL INSTRUCTIONS FOR USE	10
Protective tools	11
B. MACHINE TRANSPORT USING TRANSPORT MEANS	11
C. MACHINE HANDLING USING LIFTING EQUIPMENT	12
D. WORK SAFETY LABELS	12
1. AGGREGATION TO A TRACTOR.....	18
2. WORKING PARTS	18
3. MACHINE ASSEMBLY AT THE CUSTOMER	23
4. COMMISSIONING	23
4.1 Agregation to a tractor	24
4.2 Hydraulic of the machine	25
4.3 Folding and unfolding the machine	31
4.3.1 Putting the machine into transport position	31
4.3.2 Putting the machine into the working position	33
5. MACHINE TRANSPORT ON ROADS	36
5.1 Sharp machine projection	37
6. ADJUSTING THE WORKING PARTS OF THE MACHINE	38
6.1 Adjusting the position and depth of the track cultivators.....	38
6.2 Adjusting the spring-mounted front leveller	39
6.3 Adjusting the components of working rollers	41
6.3.1 RR- ring rollers	41
6.4 Adjusting the depth of the share section	41
6.4.1 MCD- mechanical depth setting	42
6.4.2 HD- hydraulic depth setting.....	42
6.5 Adjusting the leveller height behind shares	43
6.6 Setting the finishing section features.....	43
6.6.1 Setting the angle of the rear leveller	43
6.6.2 Setting the pressure of the finishing roller	44
7. SIDE FRAME FOLDING DRAWBARS.....	45
7.1 Adjusting the folding drawbar spring -Lp	45
7.2 Adjusting the lenght of the drawbar -Lt	46
8. AGGREGATION WITH OTHER EQUIPMENT.....	48
8.1 Transport position of the Kompaktomat three-point hitch arms.....	49
8.2 Working position of the Kompaktomat three-point hitch arms.....	50
8.3 Aggregation with pneumatic drill machine	50
8.4 Brake air pressure value setting	51
9. MAINTENANCE AND REPAIRS OF THE MACHINE	53
9.1 Lubrication plan for the machine	57
9.2 Replacement of worn shares.....	58
9.2.1 Replacement of worn shares on the central frame	58
9.2.2 Replacement of worn shares of the side frame.....	58
9.3 Specification of spare parts for axles.....	58
9.4 Replacement of the working roller bearings	59
9.4.1 Using the tool for bearing disassembly and assembly.....	60
9.4.1.1 Complete bearing disassembly.....	61
9.4.1.2 Disassembly of the ring	62
9.4.1.3 Assembling bearings onto pins.....	63
9.4.2 Using spacer.....	64
10. MACHINE STORAGE – LONG-TERM MACHINE SHUTDOWN:.....	65
11. PROTECTION OF ENVIRONMENT.....	65
12. MACHINE DISPOSAL AFTER SERVICE LIFE EXPIRY	65
13. SERVICING AND WARRANTY CONDITIONS	66
CE Certificate of Conformity	67

BASIC DESCRIPTION OF THE KOMPAKTOMAT MACHINE

The modular concept of the Kompaktomat machine design allows for variable use of its various alternatives. The machine can be attached to the tractor either via the rear arms of the three-point hitch or via the fixed bottom hitch. Furthermore, to improve the function in particular conditions, it is possible to change the working parts of the machine such as the type and number of track cultivators, type of front levellers, type of front rollers, type of share sections and type of rear rollers.

The standard version of the semi-carried machine consists of the following parts:

- Carrier bar for connecting to the three-point hitch of the pulling vehicle
- Towing forks with adjustable tractor track cultivators
- Supporting frames of the machine
- The machine is standardly equipped with a mechanical drawbar that secures the side frames in the transport position
- The machine is standardly equipped with front and rear safety plates with oblique red-and-white hatching and with taillights and a reflective plate for vehicle marking according to EHK No. 69

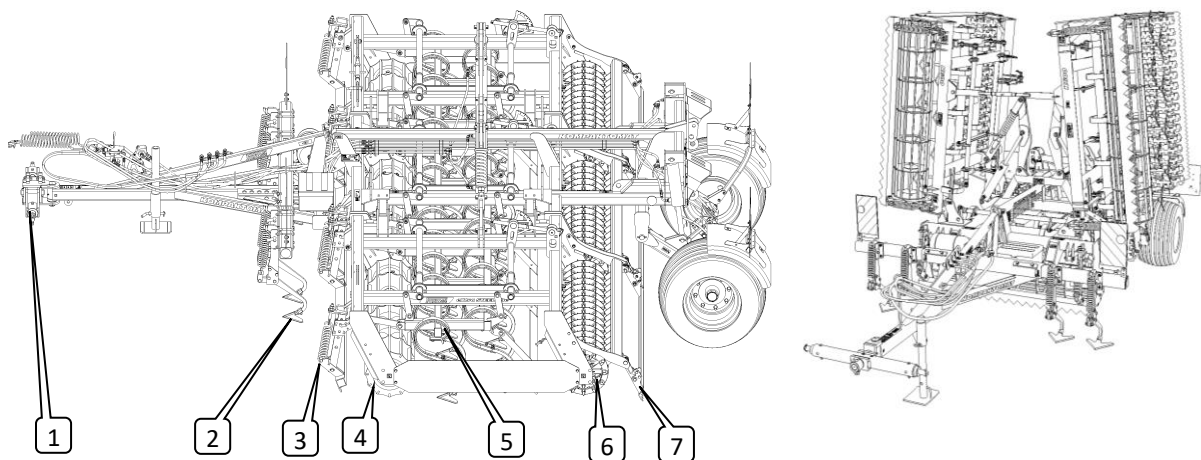

Standard Version Working parts

- 1) Tow bar
- 2) Automatically spring-loaded track cultivators
- 3) Automatically spring-loaded front levellers with height adjustment
- 4) Front roller 400mm
- 5) Height-adjustable share section with a levelling bar
- 6) Rear roller 400mm
- 7) Finish section for better soil surface quality

The control for folding the side frames into the transport or working position is designed as a single independent hydraulic circuit controlled by the driver in the tractor cabin.

The control of the axle in the transport or working position is designed as a single independent hydraulic circuit controlled by the driver in the tractor cabin.

The Kompaktomat machines meet the regulations for road traffic = width up to 3m + height up to 4m.

The design of the Kompaktomat machine allows using a whole range of additional equipment to increase productivity and efficiency.

- A. HYDRAULIC LEVELLERS...the automatic front leveller position control system using an independent hydraulic circuit controlled by the driver in the tractor cabin.
- B. HYDRAULIC DEPTH...the automatic share depth control using an independent hydraulic circuit controlled by the driver in the tractor cabin.
- C. REAR THREE-POINT HITCH ...the design of the rear three-point hitch to which it is possible to attach other equipment for soil cultivation, or a pneumatic seed drill to Kompaktomat.

TECHNICAL PARAMETERS	K500PS	K600PS	K700PS	K800PS
Working width (mm)	5000	6000	7000	8000
Transport width (mm)	3000			
Transport height (mm)	2400	2900	3400	3900
Total length of the machine (mm)	6105			
Working depth (mm)	0-100			
Number of shares AL/CF/AP	23/49/23	27/59/24	31/69/31	35/77/32
Working performance (ha/hour)	3-5	3,5-6	4,5-7	5,5-8
Working speed (km/hour)	8-12			
Maximum transport speed (km/hour)	20			
Maximum slope accessibility (°)	6			
Tyre dimensions (type)	19.0/45-17 14PR			
Tyre pressure (kPa)	400			
Max. weight of the machine (standard version)	4025	4360	4960	5345
Oil filling HLP 46 DIN51524-2 (l)	10		12	
Requirement for the engine power of the tractor (kW)*	120	130	150	160
Requirement for tractor aggregation	<i>STANDARD EQUIPMENT</i> Spacing of the bottom hitch joints (as measured on the joint axes)		1010 ± 1,5 mm	
	∅ of the bottom hitch joint holes for the hitch pins of the machine		∅37,5mm	
	<i>ABOVE-STANDARD EQUIPMENT</i> Fixed bottom hitch height		600 ± 30 mm	
	<i>ABOVE-STANDARD EQUIPMENT</i> Fixed bottom hitch aggregation mechanism		Pin ∅50mm	
			Pin ∅70mm	
Requirement for the hydraulic system of the tractor	<i>STANDARD EQUIPMENT</i> - Side frame folding circuit		Pressure in the circuit 200bar, 2 sockets for snap coupling ISO 12.5	
	<i>STANDARD EQUIPMENT</i> - Axle lifting circuit		Pressure in the circuit 200bar, 2 sockets for snap coupling ISO 12.5	
	<i>ABOVE-STANDARD EQUIPMENT</i> - Front leveller control circuit		Pressure in the circuit 200bar, 2 sockets for snap coupling ISO 12.5	
	<i>ABOVE-STANDARD EQUIPMENT</i> - Share depth control circuit		Pressure in the circuit 200bar, 2 sockets for snap coupling ISO 12.5	
	<i>ABOVE-STANDARD EQUIPMENT</i> - Drill machine drive fan circuit		PRESSURE BRANCH – circuit with oil supply priority Pressure in the circuit 130bar, 1 socket for snap coupling ISO 12.5, Maximum flow rate 40 l/min	
WASTE BRANCH – free waste into the oil tank Pressure in the circuit 5bar, 1 socket for snap coupling ISO 20				
Requirement for the air system of the tractor	<i>STANDARD EQUIPMENT</i> - Machine axle braking circuit		Pressure in the circuit at least 6bar – max. 8,5bar, 2 coupling heads of single-circuit two-hose brakes	

* These values are only as recommended tractive equipment. The actual tractive force may substantially differ according to the processing depth, soil conditions, slope of the land, wear and tear of working parts and their adjustment.



TECHNICAL PARAMETERS	K1000PS	
Working width (mm)	9850	
Transport width (mm)	3000	
Transport height (mm)	4000	
Total length of the machine (mm)	6660	
Working depth (mm)	0-100	
Number of shares AL/CF/AP	43/91/38	
Working performance (ha/hour)	8,5-10	
Working speed (km/hour)	8-12	
Maximum transport speed (km/hour)	20	
Maximum slope accessibility (°)	6	
Tyre dimensions (type)	19.0/45-17 14PR	
Tyre pressure (kPa)	400	
Max. weight of the machine (standard version)	6920	
Oil filling HLP 46 DIN51524-2 (l)	16	
Requirement for the engine power of the tractor (kW)*	180	
Requirement for tractor aggregation	<i>STANDARD EQUIPMENT</i> Spacing of the bottom hitch joints (as measured on the joint axes)	1010 ± 1,5 mm
	∅ of the bottom hitch joint holes for the hitch pins of the machine	∅37,5mm
	<i>ABOVE-STANDARD EQUIPMENT</i> Fixed bottom hitch height	600 ± 30 mm
	<i>ABOVE-STANDARD EQUIPMENT</i> Fixed bottom hitch aggregation mechanism	Pin ∅50mm
		Pin ∅70mm
Requirement for the hydraulic system of the tractor	<i>STANDARD EQUIPMENT</i> - Side frame folding circuit	Pressure in the circuit 200bar, 2 sockets for snap coupling ISO 12.5
	<i>STANDARD EQUIPMENT</i> - Axle lifting circuit	Pressure in the circuit 200bar, 2 sockets for snap coupling ISO 12.5
	<i>ABOVE-STANDARD EQUIPMENT</i> - Front leveller control circuit	Pressure in the circuit 200bar, 2 sockets for snap coupling ISO 12.5
	<i>ABOVE-STANDARD EQUIPMENT</i> - Share depth control circuit	Pressure in the circuit 200bar, 2 sockets for snap coupling ISO 12.5
Requirement for the air system of the tractor	<i>STANDARD EQUIPMENT</i> - Machine axle braking circuit	Pressure in the circuit at least 6bar – max. 8,5bar, 2 coupling heads of single-circuit two-hose brakes

* These values are only as recommended tractive equipment. The actual tractive force may substantially differ according to the processing depth, soil conditions, slope of the land, wear and tear of working parts and their adjustment.

MACHINE LIMIT PARAMETERS

- ^(x) The machine is to be used for presowing preparation of soil after ploughing or stubble breaking with working depth from 0 mm to 100 mm for soil cultivation in agriculture. Other uses exceeding the determined purpose is forbidden.
- ^(x) The machine is only operated by one person – the tractor driver.
- ^(x) Machine operator must not use the machine in a different way, especially:
 - ^(x) Transport of persons and animals on the machine structure,
 - ^(x) Transport of burdens on the machine structure,
- ^(x) Aggregation of the machine with another towing equipment than stated in Chapter „4.1./p.24“.

SAFETY STATEMENT

	This warning sign warns about an immediate dangerous situation ending with death or severe injury.
	This warning sign warns about a dangerous situation ending with death or severe injury.
	This warning sign warns about a situation that may end with a smaller or slight injury. It also warns about dangerous actions related to the activity that could lead to an injury.

A. GENERAL INSTRUCTIONS FOR USE

- A.1** ^(x) The machine is made in accordance with the latest equipment state and approved safety regulations. However, dangers of user or third person injury or machine damage or creation of other material damage may arise during use.
- A.2** ^(xx) Use the machine only in a technically sound condition, in accordance with its purpose, aware of possible dangers, and while adhering to the safety instructions of this operating manual!
The Manufacturer is not liable for damages caused by the use of the machine that is in contradiction with the limit parameters of the machine and with the instructions for the use of the machine (Chapter A and 3). The User bears the risk.
Immediately remove especially the failures that may negatively affect safety!
- A.3** ⁽⁷⁾ Machine operation may be performed by a person authorised by the operator under these conditions:
- ⁽⁸⁾ It must own a valid driver's licence of the corresponding category,
 - ⁽⁹⁾ It must be demonstrably familiarised with the safety regulations for work with the machine and must practically master the machine operation,
 - ⁽¹⁰⁾ The machine may not be operated by juveniles,
 - ⁽¹¹⁾ It must know the meaning of the safety signs located on the machine. Their respecting is important for safe and reliable machine operation.
- A.4** ⁽¹²⁾ Maintenance and servicing repairs on the machine may only be performed by a person:
- ⁽¹³⁾ Authorised by the operator,
 - ⁽¹⁴⁾ Educated in the machinery field with knowledge of repairs of similar machines,
 - ⁽¹⁵⁾ Demonstrably familiarised with safety regulations for work with the machine,
 - ⁽¹⁶⁾ During a repair of a machine connected to a tractor, it must own a driver's licence of the corresponding category.
- A.5** ⁽¹⁷⁾ Machine operator must secure the safety of other persons when working with the machine or transporting the machine.

A.6 ⁽¹⁸⁾ During machine work in the field or during transport, the operator must control the machine from the tractor's cabin.



A.7 ⁽¹⁹⁾ The operator may enter the machine structure only with the machine at rest and blocked against movement, namely only for these reasons:

- ⁽²⁰⁾ Adjustment of the machine working parts,
- ⁽²¹⁾ Repair and maintenance of the machine,
- ⁽²⁹⁾ Release and securing of spherical valves of the axle,
- ⁽²⁷⁾ Securing of spherical valves of the axle before folding the side frames,
- ⁽²⁸⁾ Adjustment of the working parts of the machine after unfolding the side frames.



A.8 ^(xxx) When stepping on the machine, do not step on tyres of the axles or other rotary parts. Those may turn and you can cause very serious injuries by the subsequent fall.



A.9 ⁽²²⁾ Any changes or modifications of machine may be performed only with written consent of the manufacturer. For possible damage arisen due to ignoring this instruction, the producer bears no responsibility. The machine must be maintained equipped with prescribed accessories and equipment including safety marking. All warning and safety signs must be legible and in their places. In case of damage or loss, these signs must be immediately renewed.

A.10 ⁽²³⁾ The operator must have the Operating Manual with the work safety requirements available at any time when working with the machine.



A.11 ⁽²⁴⁾ The operator must not consume alcohol, medicines, narcotic and hallucinogenic substances that decrease his attention and coordination capabilities while using the machine. If the operator must use medicines prescribed by a physician or uses freely sold medicines, he must be informed by a physician, whether he is capable of responsible and safe operation of the machine under these circumstances.



PROTECTIVE TOOLS

For the operation and maintenance use:

- Tight clothes
- Protective gloves and goggles for protection against dust and sharp parts of the machine



B. MACHINE TRANSPORT USING TRANSPORT MEANS

B.1 ⁽¹⁾ The transport means designed for machine transport must have the load capacity minimally identical with the weight of the transported machine. The total weight of the machine is stated on the production label.

B.2 ⁽²⁾ The dimensions of the transported machine including the transport means must comply with the valid regulations for road traffic (decrees, laws).



B.3 ⁽³⁾ The transported machine must be always fastened to the transport means so that its spontaneous loosening could not happen.

B.4 ⁽⁴⁾ The carrier is responsible for damage caused by the loosening of incorrectly or insufficiently fastened machine to the transport means.

B.5 ^(xx) The carrier shall observe the instructions of the responsible employees of Farmet in charge of loading concerning proper binding and securing of the machine on the transportation vehicle, particularly with regard to the potential damage of the machine to be transported.

C. MACHINE HANDLING USING LIFTING EQUIPMENT



- C.1 ⁽¹⁾ The lifting equipment and tying means designed for handling of the machine must have their load capacity at least identical with the weight of the handled machine.
- C.2 ⁽²⁾ Machine fastening for handling may only be performed in places designed for that and marked with self-adhesive labels showing the "chain" symbol. 
- C.3 ⁽³⁾ After fastening (suspending) at designated points, it is forbidden to move in the space of possible reach of the handled machine.
- C.4 Table with approximate weights of the parts according to the loading alternative



	K500PS	K600PS	K700PS	K800PS	K1000PS
TOWING FORK (kg)	220	220	220	220	220
CENTRAL FRAME (kg)	2100	2100	2300	2300	2400
FORK+CENTRAL FRAME (kg)	2320	2320	2520	2520	2620
RIGHT SIDE FRAME (kg)	900	1100	1500	1700	1100
LEFT SIDE FRAME (kg)	900	1100	1500	1700	1100
EXTERIOR RIGHT SIDE FRAME (kg)	-	-	-	-	1000
EXTERIOR LEFT SIDE FRAME (kg)	-	-	-	-	1000
AXLE (kg)	350	350	500	500	500
MACHINE (kg)	4150	4600	5100	5500	7000

D. WORK SAFETY LABELS

Warning safety labels serve for operator protection.

THE FOLLOWING APPLIES GENERALLY:

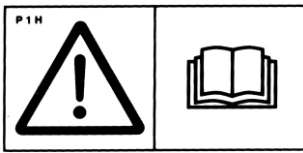
- D.1 Strictly observe the warning safety labels.
- D.2 All safety instructions also apply to other users.
- D.3 The operator shall ensure completeness and readability of labels on the machine, i.e. the operator shall replace any damaged labels with new ones.
- D.4 The appearance and exact meaning of the warning safety labels on the machine are specified in the following table.

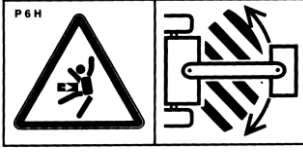
WARNING SAFETY LABELS	TEXT TO THE LABELS	POSITION ON THE MACHINE
	Before handling the machine, carefully read the operating manual. Observe the instructions and safety regulations for machine operation during use.	P 1 H
	When connecting or disconnecting, do not step between the tractor and the machine, also do not enter this space, if the tractor and the machine are not at rest and the engine is not turned off.	P 2 H
	Stay outside the reach of the tractor - agricultural machine set, if the tractor engine is in operation.	P 6 H

	<p>Secure the side frames against unfolding and the axle against sudden fall prior to the transportation of the machine.</p>	<p>P 13 H</p>
	<p>When unfolding the side frames into the transport position, do not reach into the area of contact with the central frame.</p>	<p>P 20 H</p>
	<p>Driving the machine and transportation on its construction is strictly forbidden.</p>	<p>P 37 H</p>
	<p>When working and transporting the machine, maintain safe distance from the electric appliances.</p>	<p>P 39 H</p>
	<p>Stay outside the reach of the unsecured side frames of the machine.</p>	<p>P 50 H</p>
	<p>Do not approach the rotary parts of the machine unless they are standing still, i.e. they are not rotating.</p>	<p>P 53 H</p>
	<p>It is strictly folding and unfolding the side frames on slopes or inclined surfaces.</p>	<p>P 100 H</p>
	<p>The shown positions of the handle and the function of the hydraulic ball valve located on the piston-rod.</p>	<p>P 101 H</p>
	<p>This indicates areas for hanging using handling equipment.</p>	
	<p>The mechanical stops of the axle must be used for K800PS and K1000PS in the transport position. They keep the transport height below 4m. When working in the field, switch the stops to the working position.</p>	<p>m17807</p>

D.5 The positions of the warning safety labels on the machine are shown in the following pictures.

K500PS, K600PS, K700PS, K800PS - Rear view

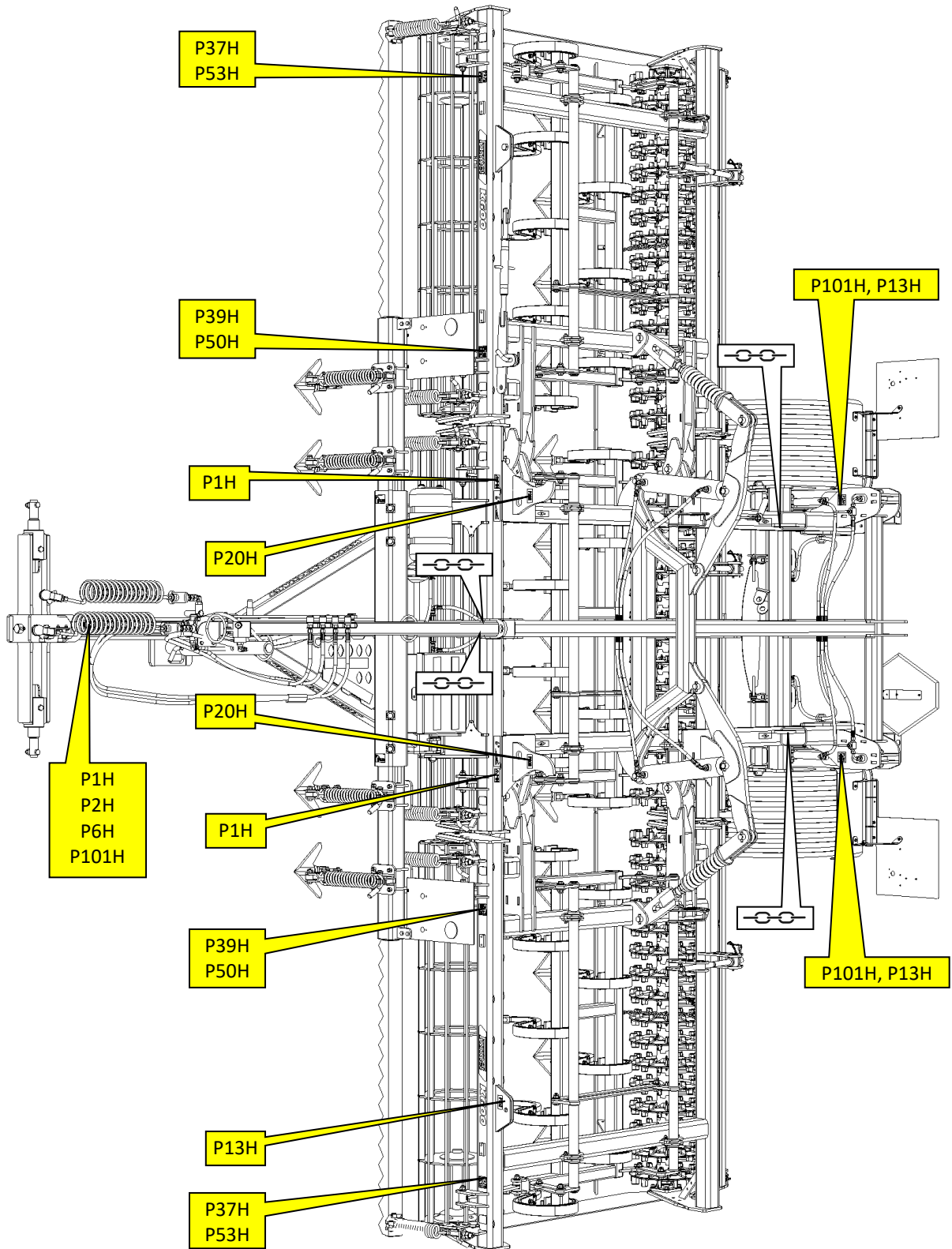

K500PS, K600PS, K700PS, K800PS - Front view

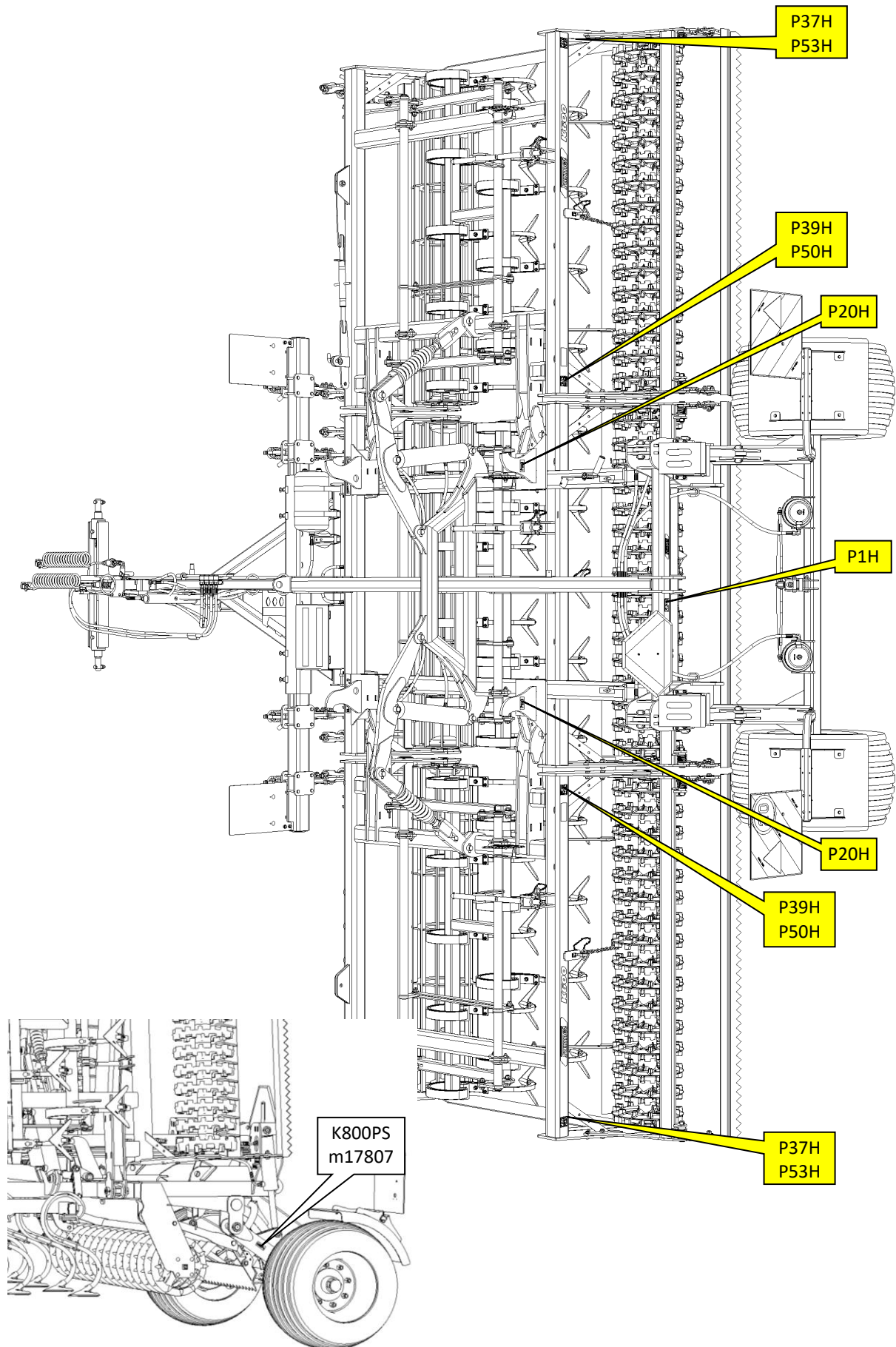

K1000PS - Rear view

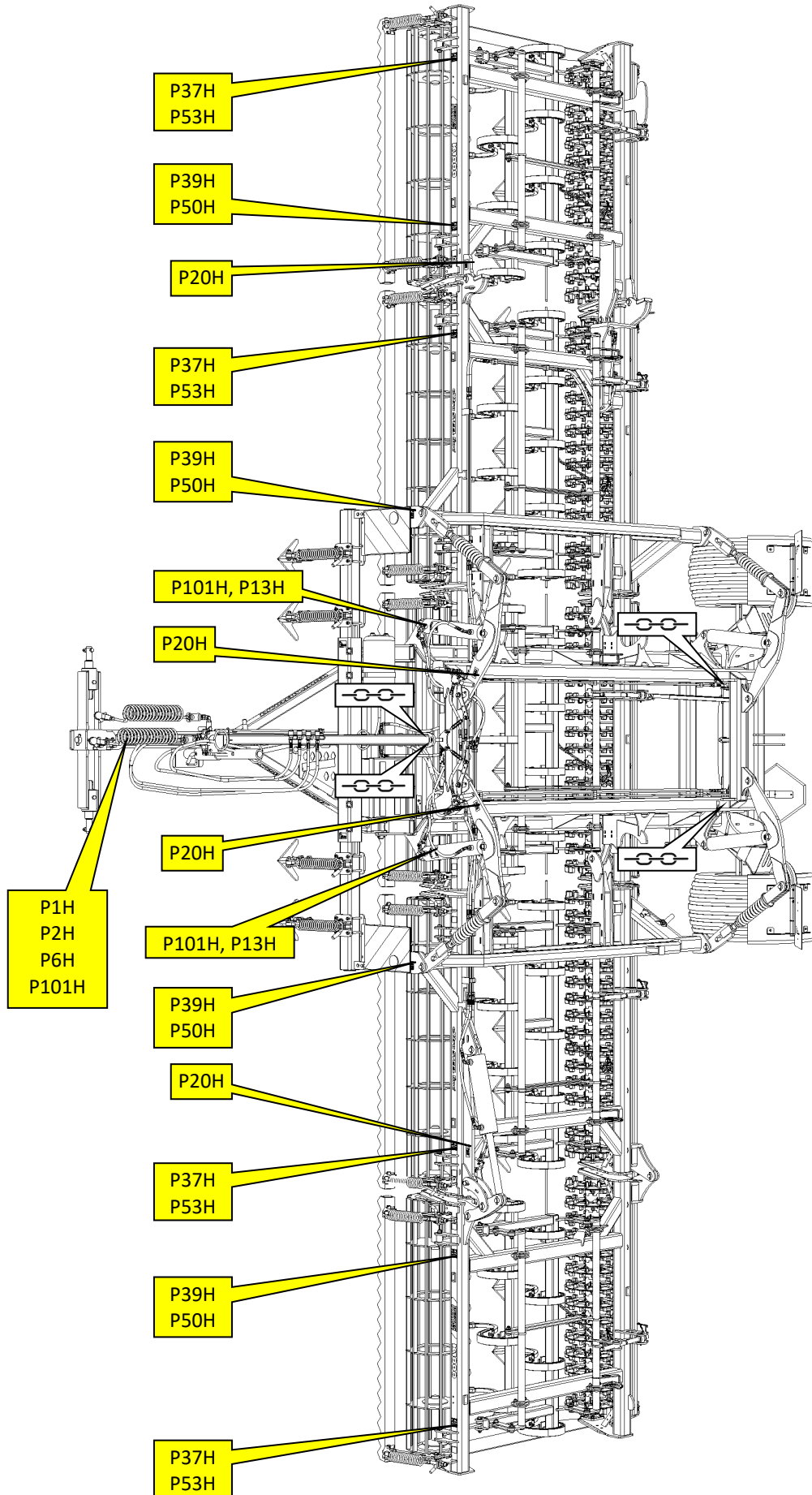

K1000PS - Front view

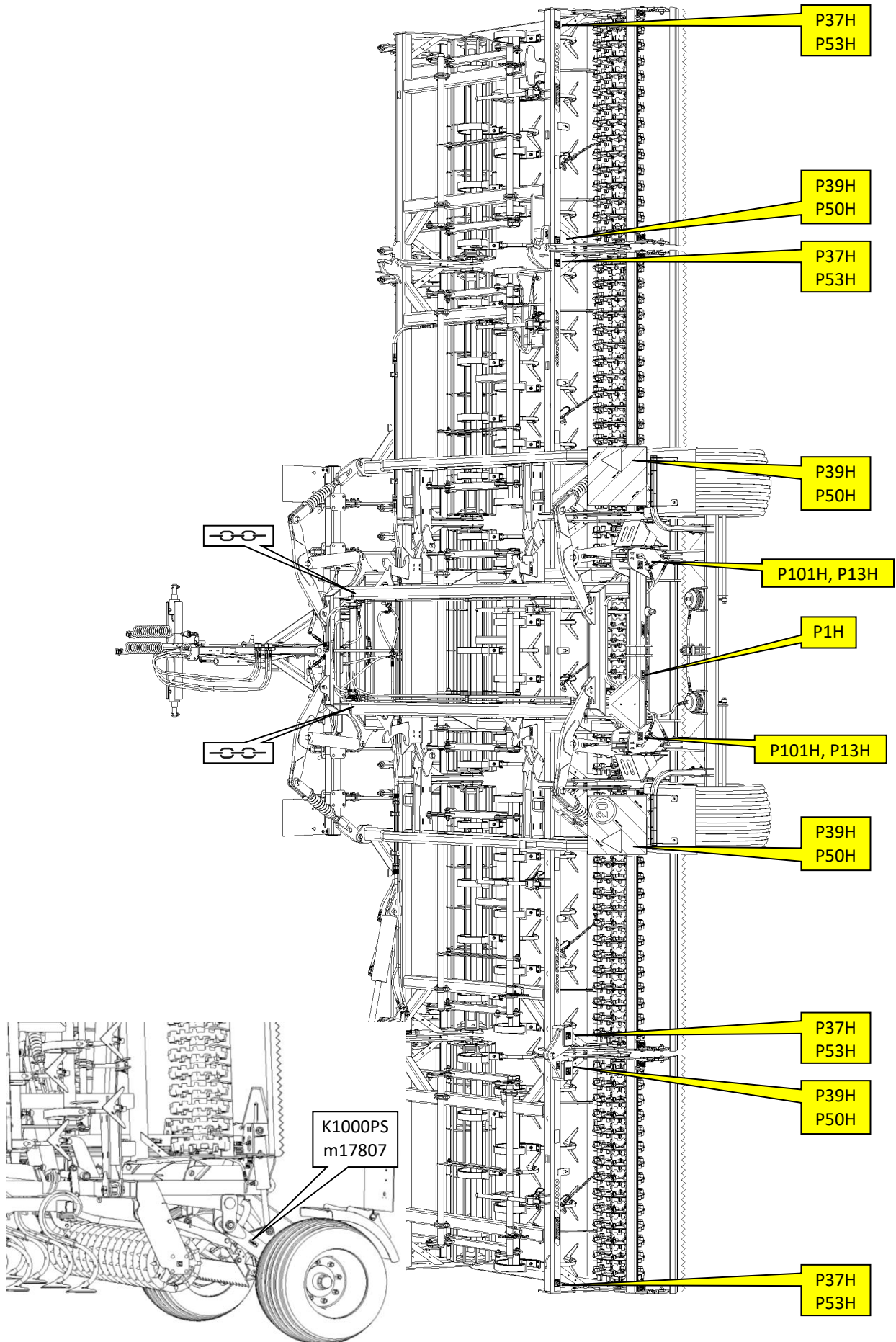

1. AGGREGATION TO A TRACTOR



TRACTOR ARM VERSION – T3; T4

Aggregation of the machine to the rear arms of the tractor in the category TBZ (three-point hitch). You can choose pins for categories TBZ3=ø36mm, TBZ4=ø50mm.

The standard version of the drawbar can be applied to tractors with width up to 3,800mm with tyres or belts. For tractors with a width exceeding 3,800mm, an extended version of the drawbar has to be used.

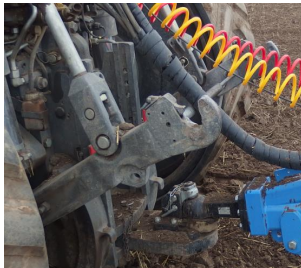

HITCH VERSION – K80; C40; C50; C70

Aggregation of the machine to the fixed bottom hitch with a K80 ball or with a pulling loop with the diameter of 40mm, 50mm or 70mm.

This is offered as the optional equipment of the machine.

The standard version of the drawbar can be applied to tractors with width up to 3,800mm with tyres or belts. For tractors with a width exceeding 3,800mm, an extended version of the drawbar has to be used.

2. WORKING PARTS

TRACK CULTIVATOR



CA – Track Cultivator with Sweep

Automatically released tractor track cultivator with a sweep. Suitable for loose types of soil where there is no risk of formation of wet clods. Possibility of mechanical depth setting up to 80mm. Possibility of setting the position directly behind the tractor wheels.



CC – Track Cultivator with Chisel Share

Automatically released tractor track cultivator with a chisel share. Suitable for heavier types of soil where there is no risk of formation of wet clods. Possibility of mechanical depth setting up to 80mm. Possibility of setting the position directly behind the tractor.

FRONT LEVELLERS

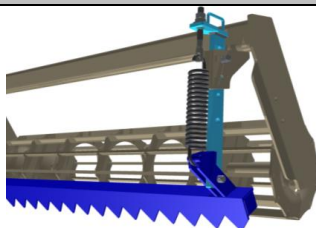

FL - FH – Front Fixed Serrated Levelling Bar

- *Automatically released levelling bar with a serrated section. Massive construction for precise levelling of coarse furrows.*
- *Possibility to adjust the height of the leveller; the leveller spring preloading may be changed.*
- *You can choose either manual adjustment of the leveller height or hydraulically controlled leveller height.*

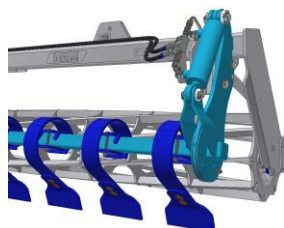

L +FB – Front Levelling Bar with Flexible Segments

- *Automatically released levelling bar with separate flexible segments.*
- *Better clod crumbling, better permeability of larger quantity of loosened soil.*
- *Possibility to change the height and the angle of the blades.*
- *You can choose either manual adjustment of the leveller height or hydraulically controlled leveller height.*

FRONT WORKING ROLLERS

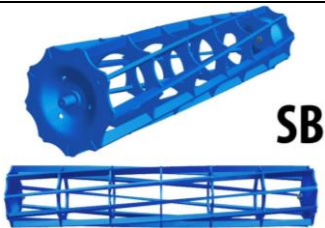

SB – Spiral Bar Roller - Ø40 cm - 60 kg/m – 9 bars

- Quality clod crumbling.
- Suitable for humid conditions.
- This type of roller can be used as the FRONT or REAR roller.

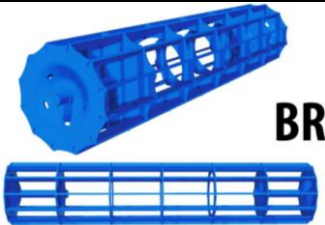

BR - Bar Roller - Ø40 cm - 60 kg/m – 12 bars

- Very good quality clod crumbling.
- Not suitable for humid conditions.
- This type of roller can be used as the FRONT or REAR roller.

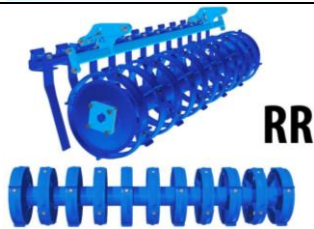

RR – Ring Roller Ø40 cm - 115 kg/m

- Quality work in all types of soil.
- Good depth guiding.
- Suitable for more humid soils.
- This type of roller can be used as the FRONT or REAR roller.

	BR	SB	RR
Crumbling	●●●○	●●●○	●●○○
Compacting	●●●○	●●●○	●●●●
Depth guiding	●●●●	●●●●	●●●●
Resistance to clogging	●●○○	●●●○	●●●●
Suitable for rocky soils	●●●○	●●●○	●●○○
Suitable for wet soils	●○○○	●●●○	●●●●
Heavy soils	●●○○	●●○○	●●○○
Medium soils	●●●○	●●●○	●●○○
Light soils	●●●●	●●●●	●●○○

● – MAX / ○ - MIN

SHARE SECTIONS

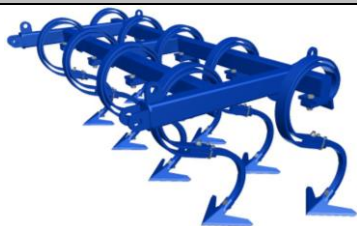

AL – Section of shares with sweeps in two rows

The share section is equipped with sweeps with the width of 25 cm in two rows. Each sweep is protected by a leaf spring. This section is suitable for lighter soil conditions without plant residues. There is a leveller behind the sweeps.



CF – Section of chisel shares in four rows

The share section is equipped with slim chisels with the width of 7 cm in four rows. The section is suitable for processing soil in spring when it is not suitable to pull wet soil out to the surface, or for heavy soils. There is **no** leveller behind the chisels.

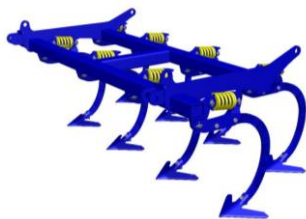

AP – Section of shares with sweeps in two rows

A universal share section is equipped with sweeps with the width of 25 cm in two rows. The sweeps are mounted to frames with geometry improving the permeability of plant residues. Therefore, this section is suitable for land with a higher occurrence of crushed plant residues as well as for heavy soils. There is a leveller behind the sweeps.

	AL	CF	AP
Number of rows of shares (pieces) / Row spacing (mm)	2 / 400	4 / 240	2 / 490
Leveller behind shares	●●●●	○○○○	●●●●
All-area processing	●●●●	●●●○	●●●●
Suitable for light soils	●●●●	●●●●	●●●●
Suitable for medium soils	●●●○	●●●○	●●●●
Suitable for heavy soils	●●●○	●●●○	●●●●
Suitable for rocky soils	●●●○	●●●○	●●●●
Suitable for wet soils	●●○○	●●●●	●●○○
Resistance to clogging	●●○○	●●●○	●●●○

● – MAX / ○ – MIN

LEVELLING BARS BEHIND SHARES

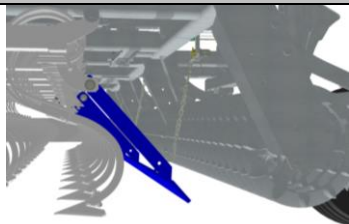

LEVELLING BAR BEHIND SHARES

The bar can be used behind all types of share sections. The bar is used for spreading the loosened soil before the rear roller. The height adjustment is performed using a chain, which the bar is suspended from.

REAR WORKING ROLLERS



SB – Spiral Bar Roller - Ø40 cm - 60 kg/m – 9 bars

- Quality clod crumbling.
- Suitable for humid conditions.
- This type of roller can be used as the FRONT or REAR roller.

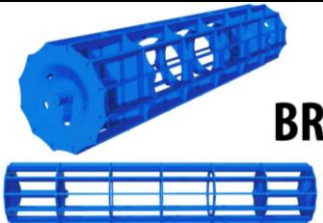

BR - Bar Roller - Ø40 cm - 60 kg/m – 12 bars

- Very good quality clod crumbling.
- Not suitable for humid conditions.
- This type of roller can be used as the FRONT or REAR roller.

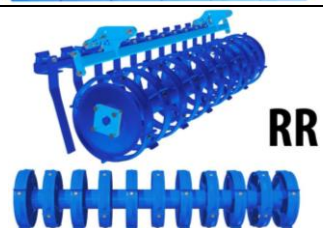

RR – Ring Roller Ø40 cm - 115 kg/m

- Quality work in all types of soil.
- Good depth guiding.
- Suitable for more humid soils.
- This type of roller can be used as the FRONT or REAR roller.

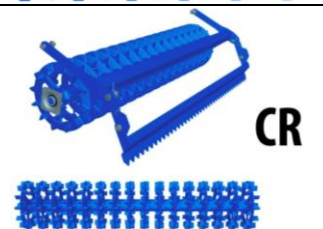

CR – Cross-kill Roller with Cleaner - Ø40 cm - 170 kg/m

- Quality clod crumbling and backwards compaction.
- Excellent work in light, medium and heavy soils.
- Not suitable for more humid soils.
- Not suitable for soils with a large quantity of rocks.
- This type of roller can be used as the REAR roller only.

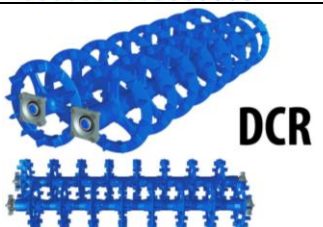

DCR – Double-row Cross-kill Roller - Ø40 cm / Ø40 cm - 175 kg/m

- Quality clod crumbling and backwards compaction.
- Mixes the processed soil more intensely.
- Excellent work in light, medium and heavy soils.
- Can work in slightly moist conditions.
- Not suitable for rocky soils.
- This type of roller can be used as the REAR roller only.

	BR	SB	CR	DCR	RR
Crumbling	●●●○	●●●○	●●●●	●●●○	●●○○
Compacting	●●●○	●●●○	●●●●	●●●○	●●●●
Depth guiding	●●●●	●●●●	●○○○	●●○○	●●●●
Resistance to clogging	●●○○	●●●○	●●●○	●●●●	●●●●
Suitable for rocky soils	●●●○	●●●○	●●○○	●○○○	●●●○
Suitable for wet soils	●○○○	●●●○	●●○○	●●●○	●●●●
Heavy soils	●●○○	●●○○	●●●○	●●●○	●●●○
Medium soils	●●●○	●●●○	●●●●	●●●●	●●●○
Light soils	●●●●	●●●●	●●●●	●●●●	●●●○

● – MAX / ○ - MIN

FINISHING OPERATIONS

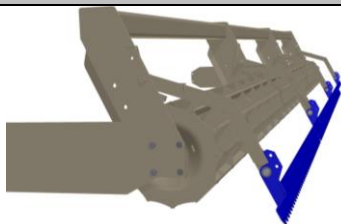

LF - REAR FINISHING LEVELLING BAR

The levelling bar behind the rear roller levels and evenly spreads the loosened soil. Possibility to change the angle of the leveller using backstop plates → thus increasing the efficiency of the leveller.

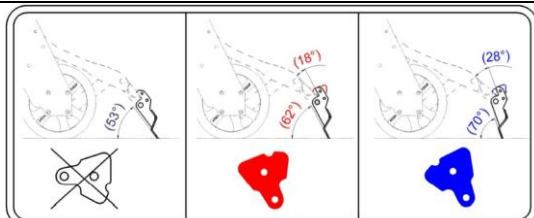

SUPPORT END STOPS OF THE FINISH LEVELLER

The end stops are used for the optional change in the finish leveller angle. When needed, it may improve the work of the leveller and the quality of the cultivated soil.

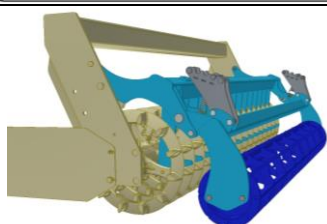

RF - REAR FINISHING ROLLER Ø220mm

The finishing roller actively disintegrates any remaining clods behind the rear roller. Possibility to change the preloading of the draw spring tension → thus increasing the efficiency of the finishing roller.
!!Be careful – the finishing roller cannot be used behind the two-row cross-kill rollers.

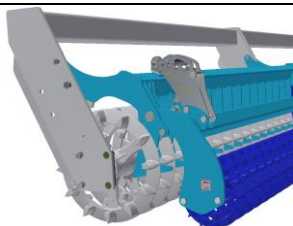

RFC – REAR FINISH CROSSKILL ROLLER Ø220mm

The Crosskill finish roller actively crumbles the remaining clods behind the rear roller. Optional change in the pre-stress of the tension spring → increases the effectiveness of the finish roller.
!!Attention: the Crosskill finish roller cannot be used after double-row Crosskill rollers.

3. MACHINE ASSEMBLY AT THE CUSTOMER

- Always assemble the machine on a flat and reinforced surface.
- Use the Spare Parts Catalogue with 3D views as reference for assembly.
- The operator must perform the assembly according to the instructions of the producer, best in cooperation with the expert servicing technician determined by the producer.
- The operator must secure a functional test of all assembled parts after the completion of the machine assembly.
- The operator must secure that the handling of the machine using lifting equipment during its assembly is in accordance with chapter „C“/p.12.
- Example of a loaded machine, K800PS, on the truck platform



- Unloading the K800PS machine from the truck platform using a forklift truck



4. COMMISSIONING

- Before taking over the machine, test and check, whether damage occurred during transport and whether all parts contained in the bill of delivery were supplied.
- Before commissioning the machine, carefully read this operating manual, especially Chapters A-D page 10-17. Before the first use of the machine, familiarise yourselves with its controls and overall function.
- During work with the machine, observe not only the instructions of this operating manual but also generally valid regulations of work safety, health protection, fire and transport safety, and environmental protection.



- The operator must check the machine before every use (commissioning) from the standpoint of completeness, work safety, work hygiene, fire safety, transport safety, and environmental protection.
- **A MACHINE SHOWING SIGNS OF DAMAGE MUST NOT BE COMMISSIONED!!**
- Aggregation of the machine with the tractor is to be performed on a flat and hardened surface.
- When working on slopes, observe the lowest slope grade of the set **TRACTOR - MACHINE**.
- Before starting the tractor motor, check whether no person or animal is in the working space of the set and push the warning sound signal.
- The operator is responsible for the safety and all damage caused by the operation of the tractor and the connected machine.
- The operator is obliged to adhere to the technical and safety regulations of the machine determined by the producer when working.
- The operator must raise the machine when turning at the plough turning end, i.e. the working parts must not be in the ground.
- The operator is obliged to observe the prescribed working depths and speeds stated in the manual in table page 8-9 when working with the machine.
- The operator is obliged to lower the machine to the ground and secure the set against movement before leaving the tractor cabin.
- **When connecting, no persons may stay in the space between the tractor and the machine. Exercise utmost caution!**



4.1 AGREGATION TO A TRACTOR

- The machine can be connected only to a tractor, whose curb weight is identical or higher than the overall weight of the connected machine.
- The machine operator must observe all generally valid regulations of work safety, health protection, fire safety, and environmental protection.
- The operator may connect the machine exclusively to a tractor that is equipped with a rear three-point hitch or lower agro tow bar and a functional undamaged hydraulic system.
- **The controlling distributors in the tractor must be secured or blocked when the machine is in the transport position or when the machine is not in use to prevent accidental or third-party (children, passengers) caused movement of the hydraulics.**
- Aggregate the machine with the tractor using type and dimensionally consistent components corresponding to the output requirements. For example, do not aggregate a machine with $\varnothing 50\text{mm}$ pulling loop to $\varnothing 40\text{mm}$ pin!
- The design allows selecting from several versions of aggregation to the tractor.



Aggregation to the rear TBZ hitch



Aggregation to the agro tow bar = K80, C40, C50, C70

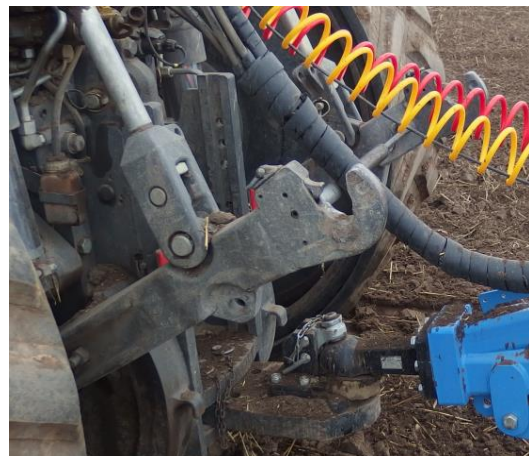

HYDRAULIC OIL SPECIFICATIONS

The hydraulic circuit of the machine is filled with oil at the factory:

Performance level: API GL 5; SAE 10W-30; SAE 80





Manufacturer’s specification: ALLISON C4; CATERPILLAR TO-4; VOLVO VCE WB 101; 97303 JONH DEERE 20C/20D ZF TE-ML 03E/05F/06E/06F/06K/17E/21F; PARKER DENISON HF-0/HF-1/HF-2 New HOLLAND NH 420A/410B MASSEY FERGUSON M1135/M1141/M1143/ M1145 KUBOTA UDT Fluid CASE IH MS-1204/MS-1206/ MS-1207/MS-1209 FORD M2C134D M2C86B/C CNH MAT 3525/ MAT3526 SPERRY VICKERS/EATON M2950S, I-280-S SAUER SUNDSTRAND(DANFOSS) Hydro Static Trans fluid; CASE CNH MAT 3540(CVT), Claas(CVT), AGCO CVT; ML200, Valtra G2-10(XT-60+)

4.2 HYDRAULIC OF THE MACHINE











Parts of the hydraulic system of the machine, which are under pressure, are forbidden to disassemble. Hydraulic oil that penetrates the skin under high pressure causes severe injuries. In case of injury, seek a physician immediately.

- Connect the hydraulics only when the hydraulic circuits of the machine and the tractor (aggregate) are in a pressure-less condition.
- The hydraulic system is under high pressure. Regularly check for leaks and immediately remove obvious damage of all lines, hoses, and pipe unions.
- When seeking and removing leaks, use only the suitable tools.
- For connecting the hydraulic system of the machine to the tractor, use the plug (on the machine) and the socket (on the tractor) of the quick-couplers of the same type.
- For simplification, the hydraulic circuits are marked by different colours.

	<p>HYDRAULIC CIRCUIT FOR SIDE FRAME FOLDING - ONE RED RING Pressurizing this branch of the circuit folds side frames into the transport position.</p>	<p>Flow limiters reducing the speed of the piston-rod operation are used in the circuit. The precise position can be found in the Spare Parts Catalogue.</p>
	<p>HYDRAULIC CIRCUIT FOR SIDE FRAME FOLDING - TWO RED RINGS Pressurizing this branch of the circuit unfolds side frames into the working position.</p>	
	<p>HYDRAULIC CIRCUIT FOR AXLE CONTROL - ONE YELLOW RING Pressurizing this branch of the circuit brings the axle into the position when the machine rides on the working rollers and the axle wheels are in the air.</p>	
	<p>HYDRAULIC CIRCUIT FOR AXLE CONTROL - TWO RED RINGS Pressurizing this branch of the circuit lifts the transport axle into the transport position, i.e. the machine rides on the axle tyres.</p>	

HYDRAULIC CONTROL OF THE DRAW BAR FOR THE BOTTOM-HITCH VERSION

	STANDARD EQUIPMENT OF THE MACHINE	HYDRAULIC CIRCUIT FOR THE SUPPORT LEG CONTROL - ONE BLACK RING Pressurizing this branch of the circuit lifts the support leg off the ground towards the drawbar construction.	Flow limiters reducing the speed of the piston-rod operation are used in the circuit. The precise position can be found in the Spare Parts Catalogue.
			
	OPTIONAL EQUIPMENT OF THE MACHINE	HYDRAULIC CIRCUIT FOR FRONT LEVELLER POSITION CONTROL - ONE BLUE RING Pressurizing this branch of the circuit brings the leveller up from the surface.	Flow limiters reducing the speed of the piston-rod operation are used in the circuit. The precise position can be found in the Spare Parts Catalogue.
		HYDRAULIC CIRCUIT FOR FRONT LEVELLER POSITION CONTROL - TWO BLUE RINGS Pressurizing this branch of the circuit recesses the leveller to the surface.	
		HYDRAULIC CIRCUIT FOR SHARE WORKING DEPTH CONTROL - ONE GREEN RING Pressurizing this branch of the circuit brings shares out of the processed profile.	
		HYDRAULIC CIRCUIT FOR SHARE WORKING DEPTH CONTROL - TWO GREEN RINGS Pressurizing this branch of the circuit recesses shares into the processed profile.	
		HYDRAULIC CIRCUIT FOR DRILL MACHINE FAN FLUID MOTOR DRIVE - ONE BLACK RING + ONE BLUE RING The Dn20 circuit branch is used for draining oil directly into the oil tank of the tractor. The maximum permissible pressure in the waste hose is 5 bar ; higher pressure pushes the shaft sealing out which damages the fluid motor fan. If no suitable outlet into the tank is not installed in the tractor, consult the manufacturer (dealer) of the tractor who will provide information about the possibilities of a free waste end piece.	
		HYDRAULIC CIRCUIT FOR DRILL MACHINE FAN FLUID MOTOR DRIVE - TWO BLACK RINGS + ONE BLUE RING The Dn12 circuit branch is connected to the circuit with oil delivery priority. Pressurizing this branch of the circuit delivers oil to the fluid motor drive of the fan. The maximum permissible pressure is 130 bar, maximum flow rate is 40 l/min.	

Hydraulic diagram K500-800PS

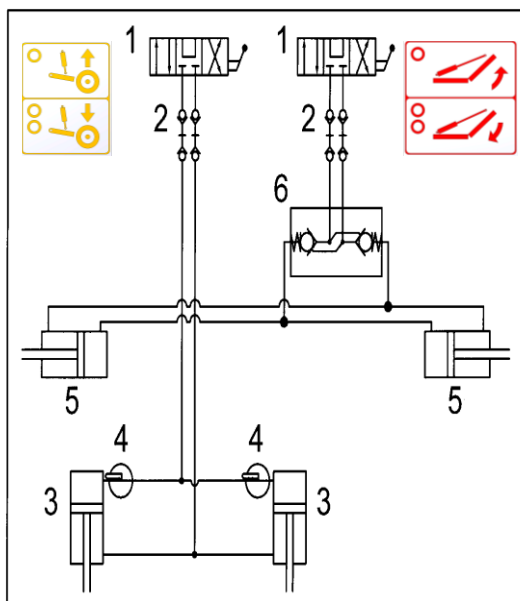

- 1-Control distributor in the tractor
- 2-Hydraulic snap couplings
- 3-Hydraulic cylinders of the axle control
- 4-Closing taps of the axle cylinders
- 5-Hydraulic cylinder of side frame unfolding
- 6-Hydraulic closing valve of the cylinder for side frame unfolding

Hydraulic diagram K500-800PS-FRONT LEVELLER POSITION CONTROL

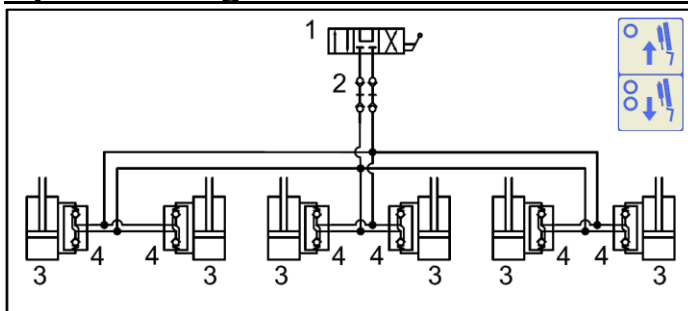

- 1-Control distributor in the tractor
- 2-Hydraulic snap couplings
- 3-Hydraulic cylinders of leveller control
- 4-Hydraulic closing valve for leveller cylinders

Hydraulic diagram K500-800PS-SHARE WORKING DEPTH CONTROL

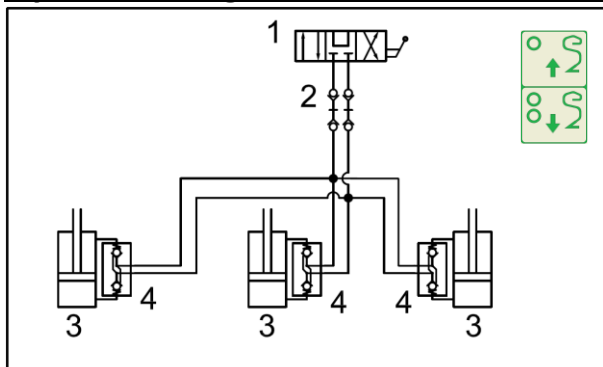

- 1-Control distributor in the tractor
- 2-Hydraulic snap couplings
- 3-Hydraulic cylinders of share depth control
- 4-Hydraulic closing valve for share depth cylinders

Hydraulic diagram K1000PS

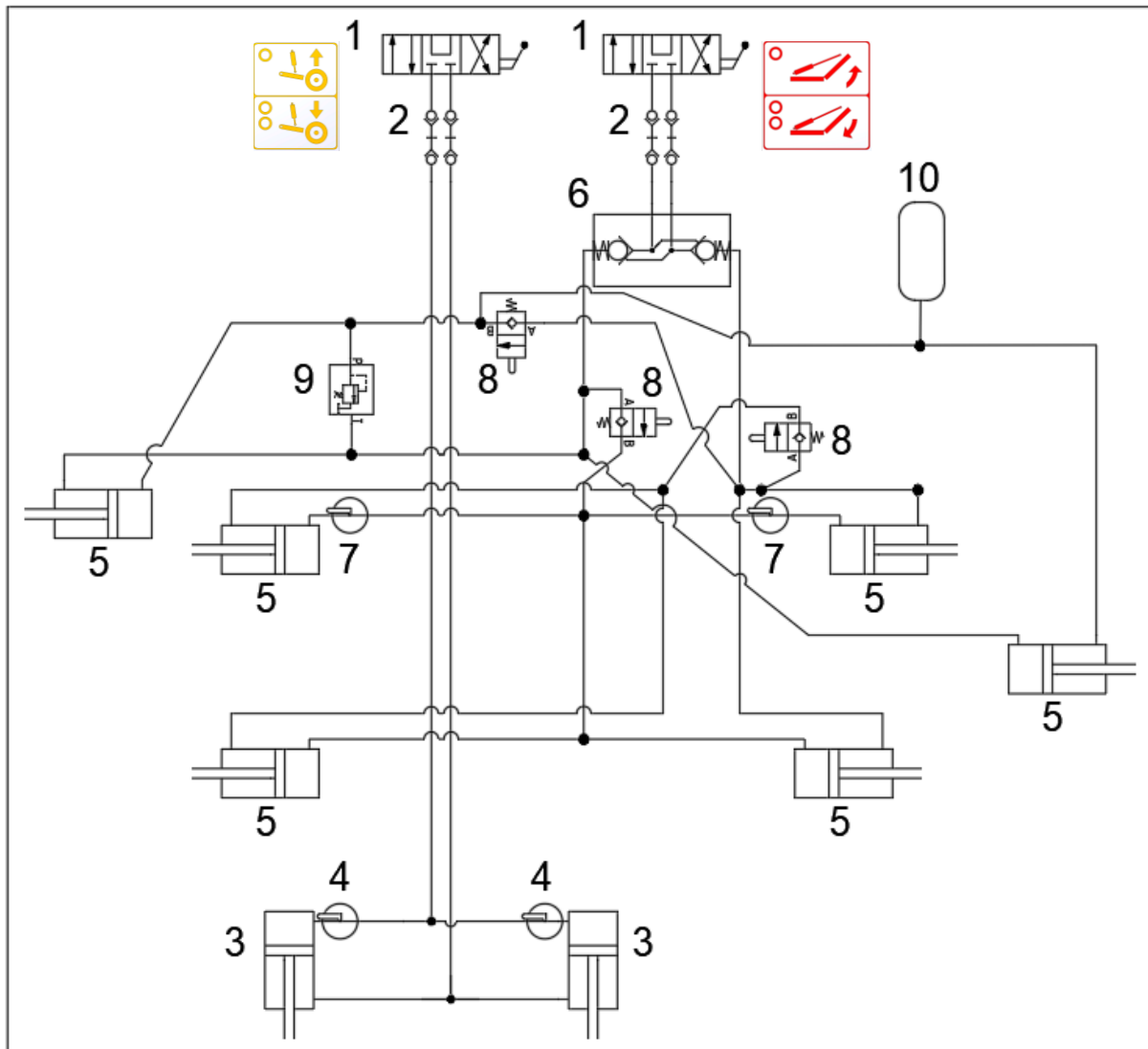

- 1-Control distributor in the tractor
- 2-Hydraulic snap couplings
- 3-Hydraulic cylinders of the axle control
- 4-Closing taps of the axle cylinders
- 5-Hydraulic cylinders of side frame unfolding
- 6-Hydraulic closing valve of cylinders for side frame unfolding
- 7-Closing taps for the control of cylinders for side frame unfolding
- 8-Transfer valve for the control of functions of side frame unfolding
- 9-Securing valve for the control of functions of side frame unfolding
- 10-Pressure accumulator, gas pressure in the container = 200 bar

Hydraulic diagram of the support leg K500PS-K1000PS

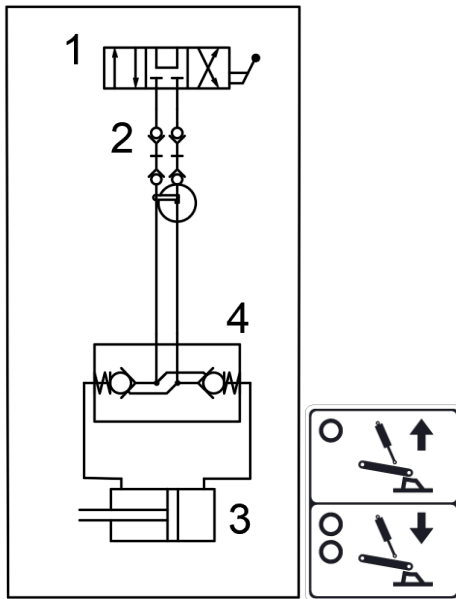

Hydraulic diagram K1000PS-FRONT LEVELLER POSITION CONTROL

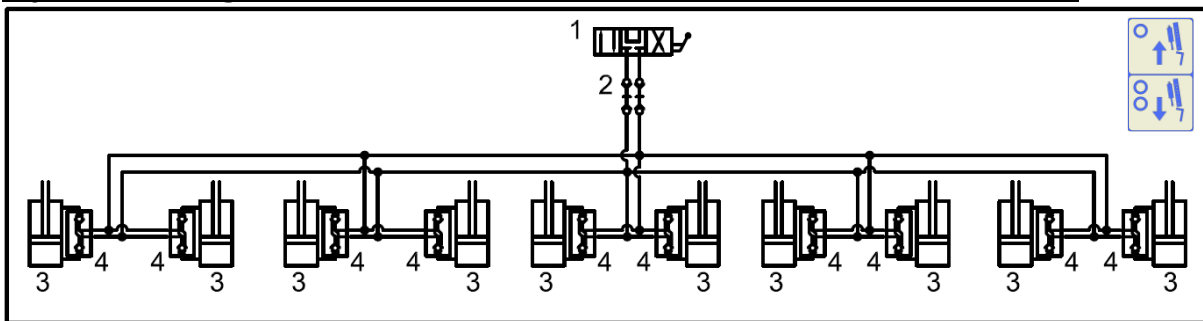

- 1-Control distributor in the tractor
- 2-Hydraulic snap couplings
- 3-Hydraulic cylinders of leveller control
- 4-Hydraulic closing valve for leveller cylinders

Hydraulic diagram K1000PS- SHARE WORKING DEPTH CONTROL

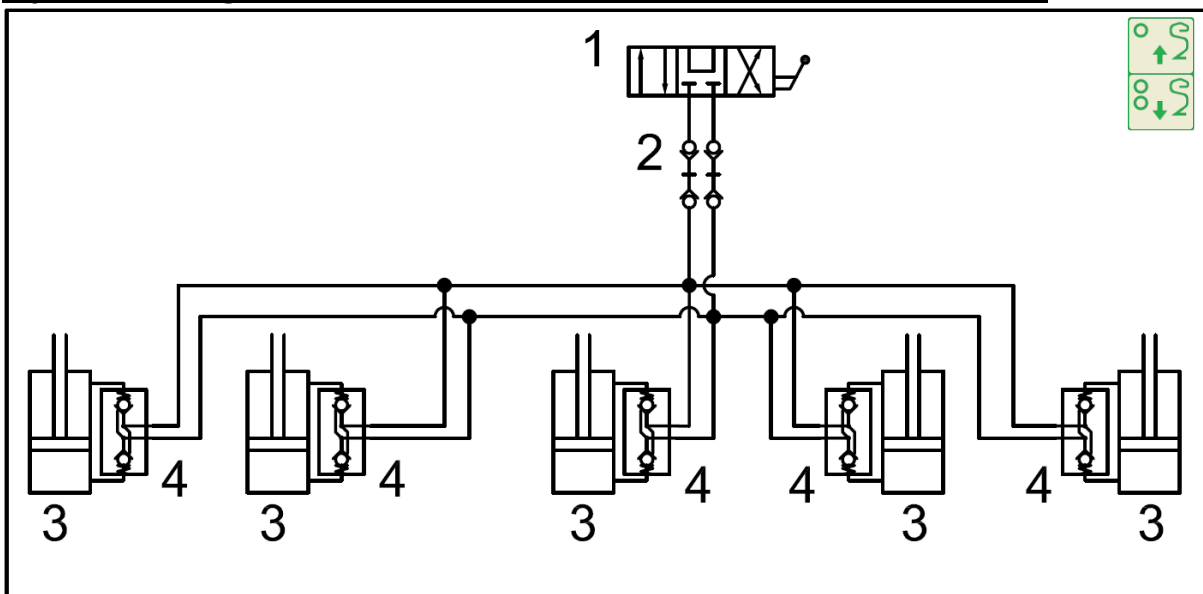

- 1-Control distributor in the tractor
- 2-Hydraulic snap couplings
- 3-Hydraulic cylinders of share depth control
- 4-Hydraulic closing valve for share depth cylinders

Hydraulic diagram - K500-K1000 SEED DRILL FAN DRIVE

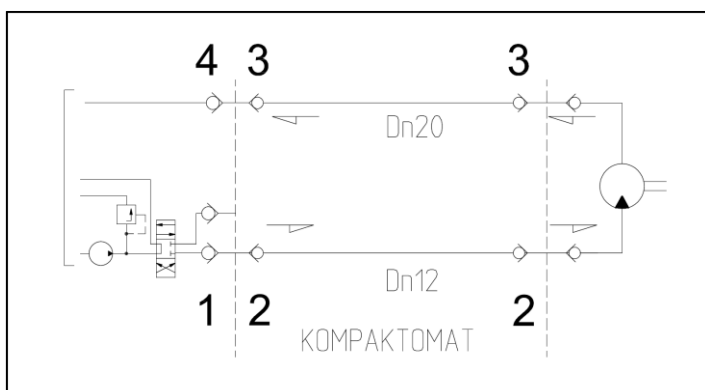

- 1-Control distributor in the tractor
- 2-Hydraulic snap couplings ISO 12,5
- 3- Hydraulic snap couplings ISO 20
- 4-Loose waste to the tractor tank

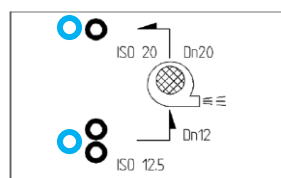

4.3 FOLDING AND UNFOLDING THE MACHINE



When executing any of the hydraulic movements, slow down the moving parts of the machine before position stop by choking a relevant valve on the tractor control!



- The hydraulics for the folding and unfolding must be connected to the double-action hydraulic circuit.
- The operator must ensure that there are no people or animals within the reach of the side frames during their unfolding or folding (i.e. in the place of their position stop) and that no one puts their fingers or other body parts into the area of the joints.
- Execute unfolding or folding on flat and solid surfaces or crosswise to a slope.

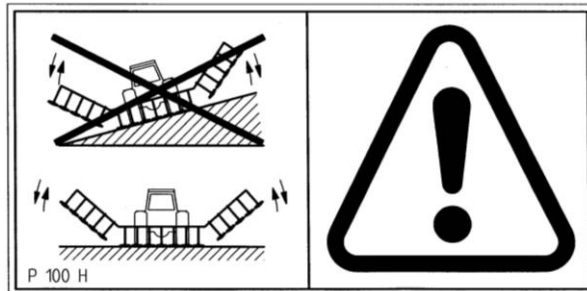

- Unfold or fold the machine only when it is lifted on the axle.
- Remove any soil stuck on the folding places as it may disturb the function and cause damage to the mechanics.
- During folding or unfolding, check the side frames and have them continuously fold into the end position to the stoppers.

4.3.1 PUTTING THE MACHINE INTO TRANSPORT POSITION

➤ LIFT THE MACHINE UP ON THE AXLE

- Lift the machine on the axle by pressurizing the hydraulic circuit marked with two yellow rings. Continue lifting until the piston-rod is drawn out to the end position. At the same time, lift the rear arms of the tractor, if the machine is aggregated in this way. If the machine is aggregated to the fixed bottom hitch of the tractor, the machine is lifted automatically with the axle.

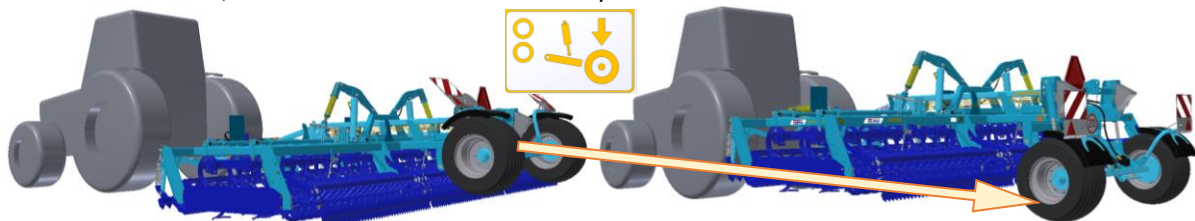

- Clean the machine from impurities.

➤ FOLD THE SIDE FRAMES INTO THE TRANSPORT POSITION

- Pressurizing the hydraulic circuit marked with one red ring continuously folds the side frames into the transport position. The machine is factory-set so that the side frames rest on the stops of the central frame when the piston-rod is drawn out to the maximum position.
- In K1000PS, the process of folding is automated, i.e. the machine folds automatically when the circuit is pressurized.

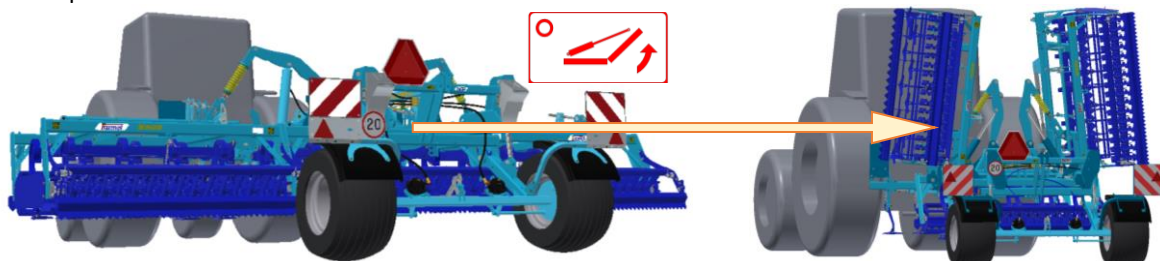

- Block or close the circuit.

- SECURE THE SIDE FRAMES AGAINST UNFOLDING ...K500-800PS
 - When the machine is folded into the transport position, you have to secure the side frames against unfolding by the mechanical connecting rod.

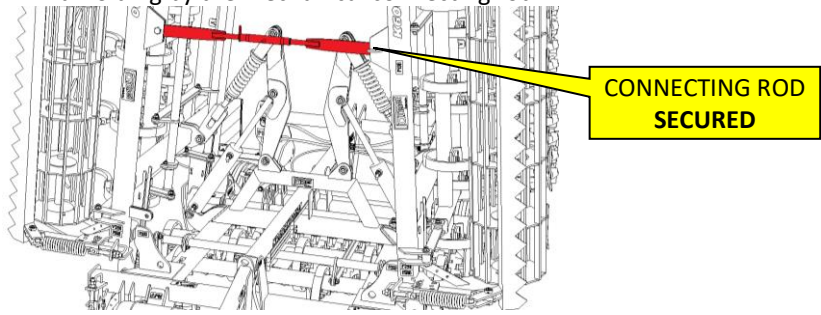

- SECURE THE SIDE FRAMES AGAINST UNFOLDING ...K1000PS
 - When the folding of the machine into the transport position is complete, the side frames must be secured by setting the ball valves on the front piston-rods into the "closed" position.

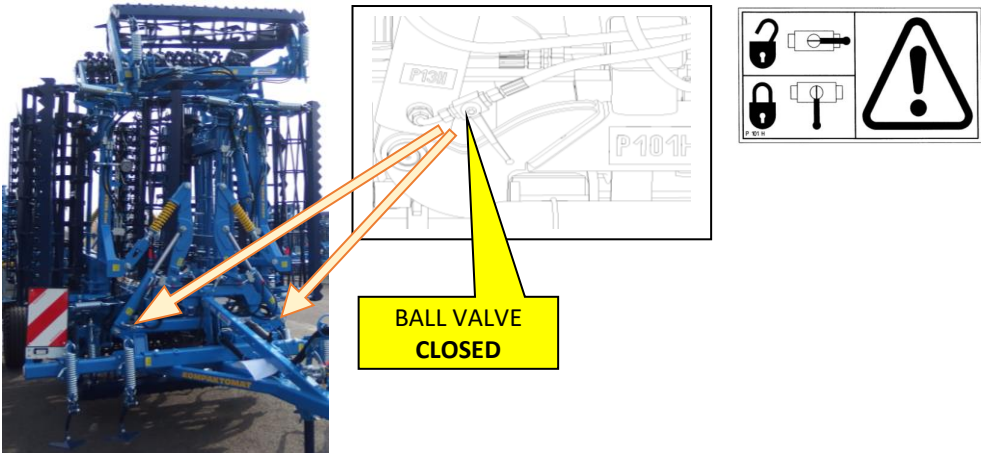

- SECURE THE POSITION OF THE TRANSPORT AXLE ...K500-700PS
 - When the folding of the machine into the transport position is complete, the axle in the transport position must be secured by setting the axle ball valves into the "closed" position.

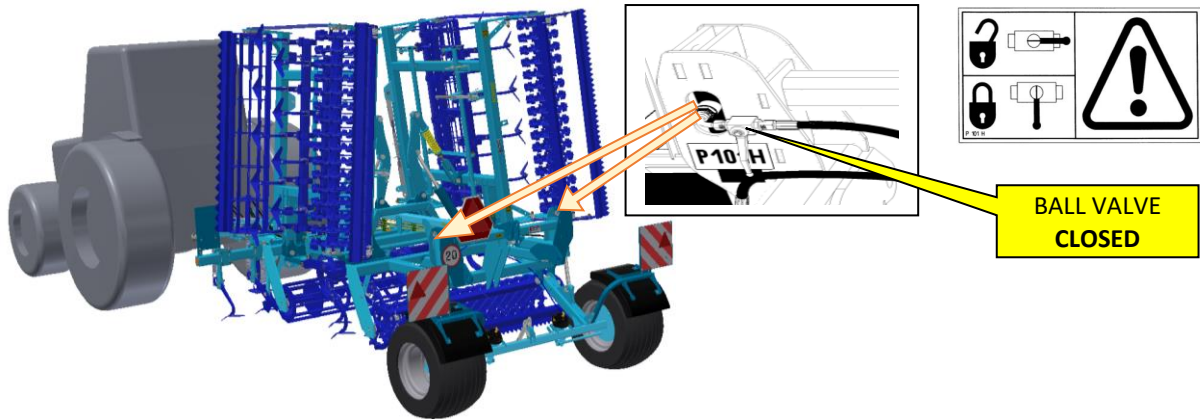

- SECURE THE POSITION OF THE TRANSPORT AXLE ...K800-1000PS = TRANSPORT HEIGHT UP TO 4m
 - When the folding of the machine into the transport position is complete, the axle must be secured in the transport position by flipping the backstop of the axle. Secure the backstop with a pin so that it cannot come loose. Then, release the axle control circuit (MARKED WITH YELLOW RINGS) from the driver's position into the floating position to lower the machine down to the end, thus achieving the transport position of 4m.

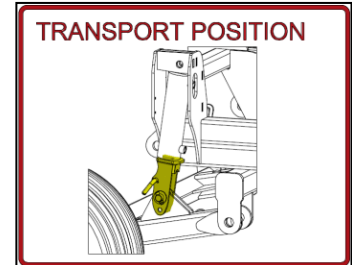
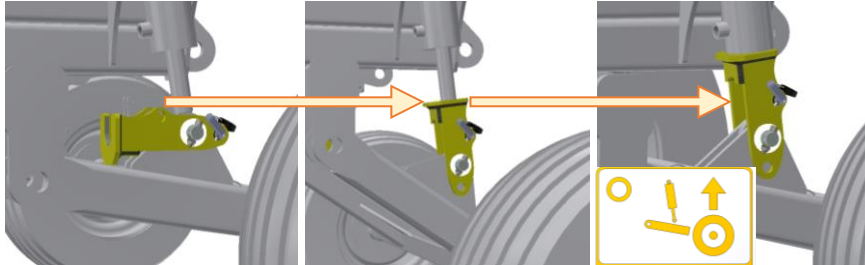

4.3.2 PUTTING THE MACHINE INTO THE WORKING POSITION

- RELEASE THE SIDE FRAMES BEFORE UNFOLDING ...K500-800PS
 - Before starting to unfold the K500-800PS machines, you must release the mechanical connecting rod. Failure to do so will damage the machine.

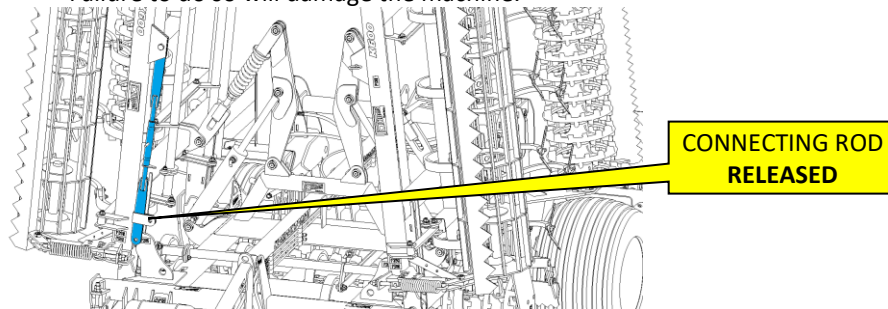

- RELEASE THE SIDE FRAMES BEFORE UNFOLDING...K1000PS
 - Before starting to unfold the K1000PS machine, you must release the ball valves on the piston-rod for unfolding into the "OPEN" position.

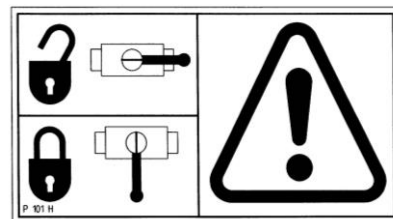
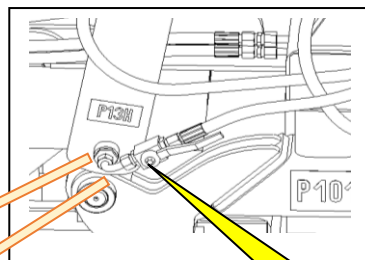

➤ RELEASE THE SIDE FRAMES INTO THE WORKING POSITION

- Unfold the side frames continuously into the working position by pressurizing the hydraulic circuit marked with two red rings.
- In K1000PS, the process of unfolding is automated, i.e. the machine unfolds automatically when the circuit is pressurized. Pressurize the circuit until the machine is fully unfolded and the piston-rods are completely drawn in.

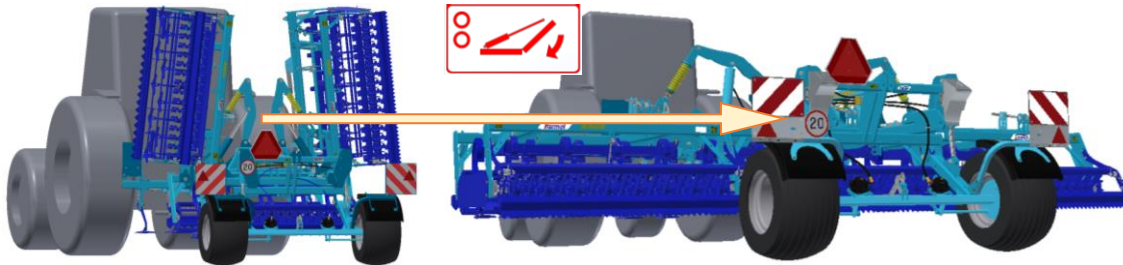

- In order to eliminate pressure peaks in the piston rod in the outer right frame of the machine (in the travelling direction) into the hydraulic circuit, a pressure accumulator set to 200 bar is installed for the working position of K1000PS.

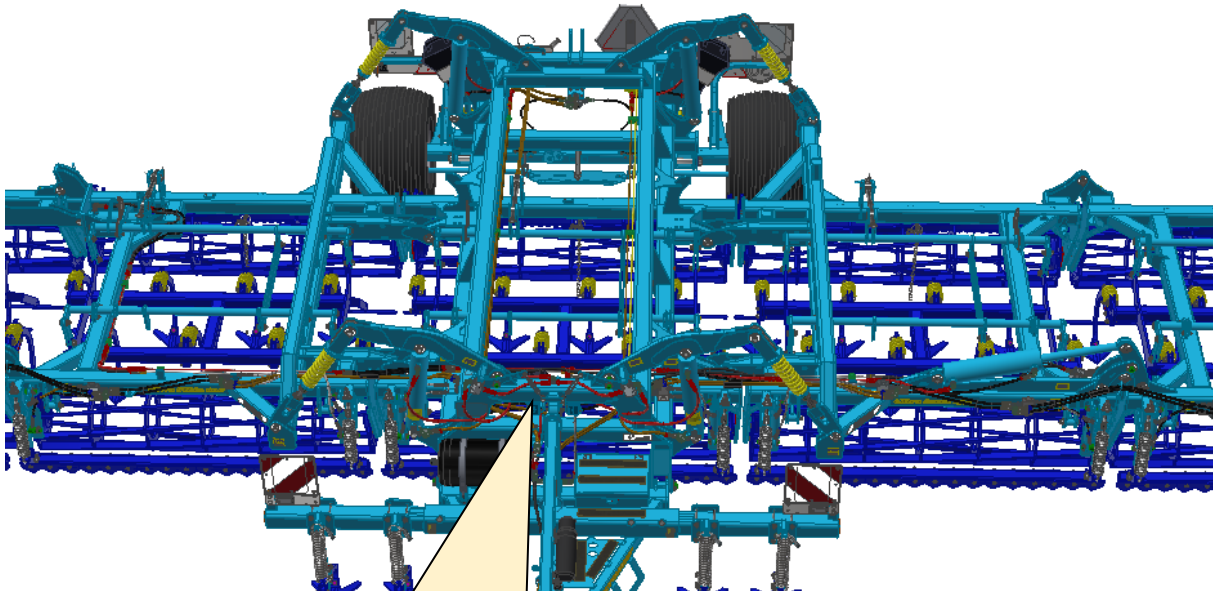

- RELEASE THE POSITION OF THE TRANSPORT AXLE ...K500-700PS
 - When unfolding into the working position is complete, the ball valve of the piston-rod must be released from the transport position to the “open” position.

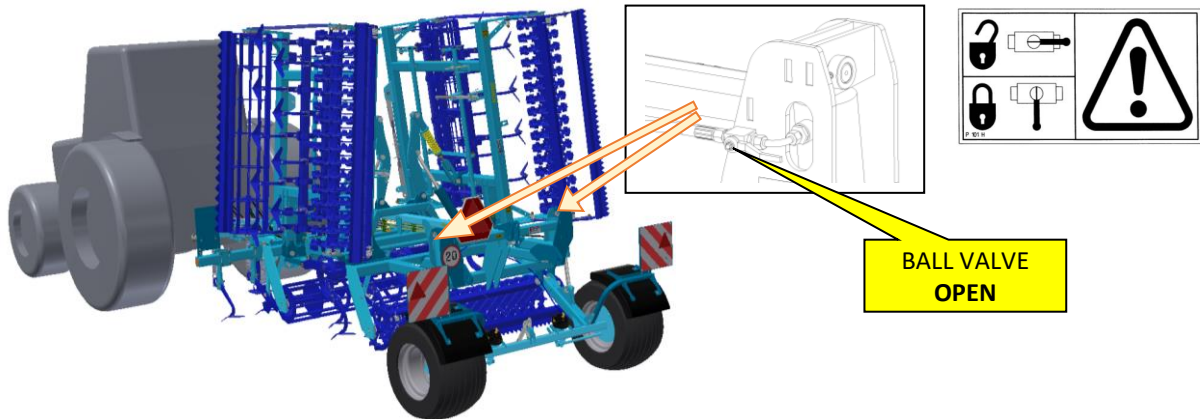

- RELEASE THE POSITION OF THE TRANSPORT AXLE ...K800-1000PS
 - When unfolding into the working position is complete, the machine must be lifted from the axle backstop by pressurizing the hydraulic circuit marked with two yellow rings. Then, release the axle from the transport position by flipping the backstop. Secure the backstop with a pin so that it cannot come loose. Then, release the axle control circuit from the driver’s position into the floating position to lower the machine down to the end, thus achieving the transport position of 4m.

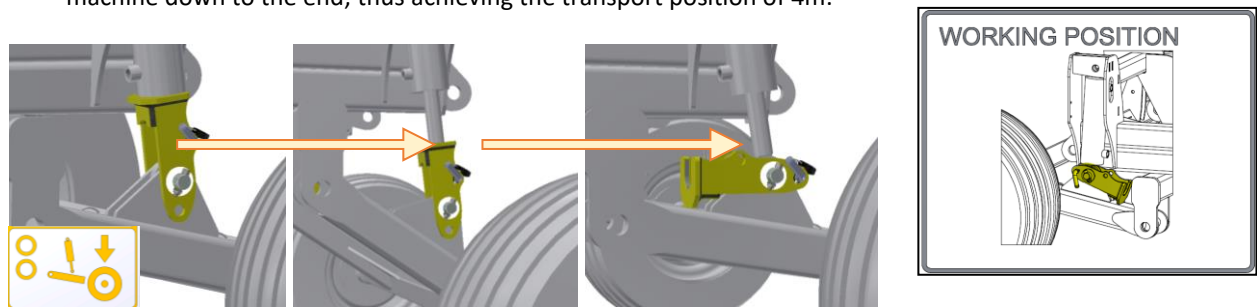

- PLACE THE MACHINE ON THE WORKING ROLLERS
 - Lower the machine down to the ground by pressurizing the hydraulic circuit marked with one yellow ring. Continue until the piston-rod is completely drawn in and the travelling wheels are lifted above the ground. The machine is standing on its working parts (rollers or shares). At the same time, lower the rear arms of the tractor, if the machine is aggregated in this way. If the machine is aggregated to the fixed bottom hitch of the tractor, the machine is lifted automatically with the axle. If the machine is aggregated to the fixed bottom hitch of the tractor, the machine is lowered automatically with the axle control.

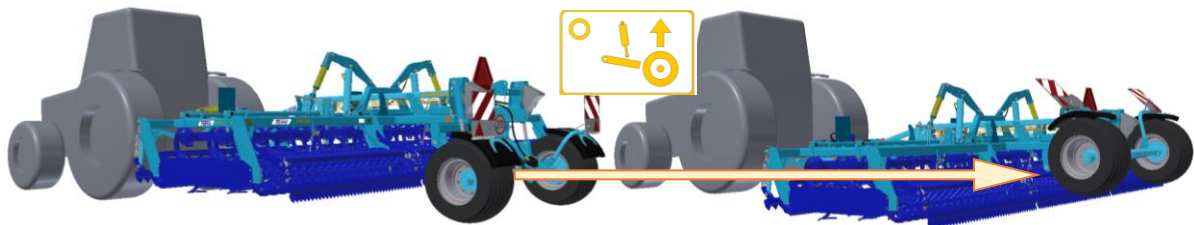

- Block or close the circuits.

5. MACHINE TRANSPORT ON ROADS

- According to Chapter 4.3.1, the machine must be put into the transport position, i.e. the machine is folded, the side frames are secured against unfolding and the ball valves of the transport axle are secured.
- Mechanical axle stops must be used for K800PS and K1000PS machines in order to observe the transport height below 4m.
- The machines are equipped with reflective plates in the front and in the rear that outline the exterior profile. The operator shall keep the plates clean and free from any damage.
- The operator must clean the machine of any dirt to prevent the contamination of the roads before setting off.
- The operator must prepare the machine for the transportation so that it meets the valid regulations, directives and ordinances for road transportation.
- The operator is obliged to pay increased attention during transport on roads, due to the transport dimensions of the machine.
- The operator must observe the valid regulations for transport on roads (laws, decrees) after connecting the machine to the tractor, for reason of a change of the axle load. The driving properties of the set also change depending on the terrain nature, adapt the manner of driving to these conditions.
- The operator is obliged to present the machine certificate of roadworthiness as needed, according to the valid regulations for road traffic (decree, law) (only in the Czech Republic).
- The operator is obliged to secure sufficient outlook during reversing from his position of the tractor driver. In case of insufficient outlook, the operator is obliged to call a competent and informed person.
- If the machine is aggregated behind the tractor with the rear arms of the three-point hitch, the operator must secure the three-point hitch rear arms of the tractor in the transport position when transporting the machine on roads, i.e. prevent sudden drop of the arms by the hydraulic shoulder control lever. At the same time, the arms of the rear TPH of the tractor must be secured against side swinging.
- During machine transport on roads, the operator must observe the valid laws and decrees that deal with this topic and which specify the relationships of the tractor axle load depending on transport speed.
- **IT IS FORBIDDEN TO TRANSPORT THE MACHINE ON ROADS WHEN VISIBILITY DISTANCE IS REDUCED!!**



Checking the nuts on the transport axle

- Use the plastic arrow “Check Point” to check for loose nuts. It promptly shows the condition of the nuts, whether they are loose or not.
- Always check the Check Points before driving.
- When the arrows are not facing one another, the nuts have to be tightened to the required torque and the Check Point arrows have to point against one another as shown in the green picture.

Torque for the axle nuts:

M18x1,5 - 265Nm

M20x1,5 - 343Nm

M22x1,5 - 440Nm

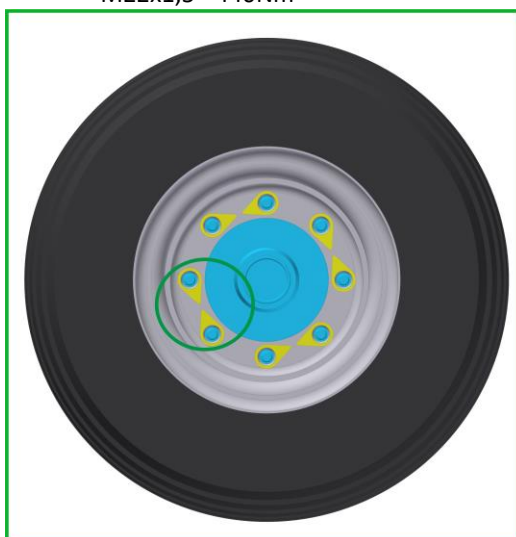

INITIAL POINT-TO-POINT CONFIGURATION

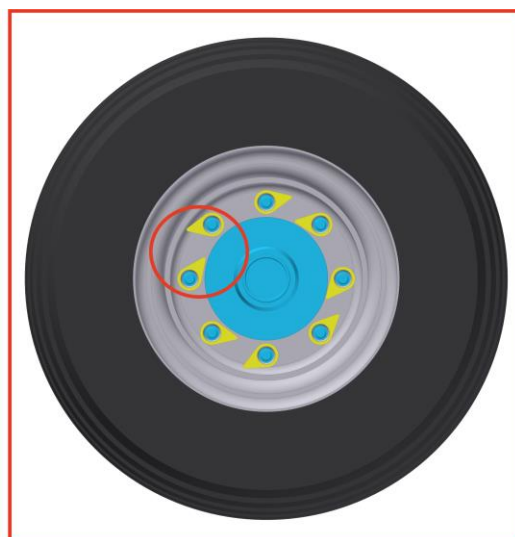

DANGER – WHEEL NUTS HAVE LOOSENED!

5.1 SHARP MACHINE PROJECTION



- The machine contains sharp structural projections.
- **It is prohibited to operate and transport the machine on roads when visibility is reduced!!** - Persons or objects, or other road traffic participants could get caught.
- **The machine operator must be extra cautious when driving on roads and consider the width of the machine and safe distance from persons, vehicles and objects, or other road traffic participants!!**

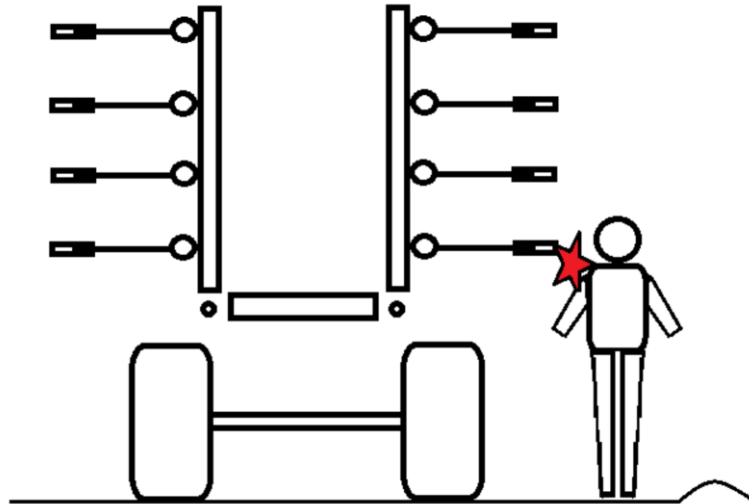

6. ADJUSTING THE WORKING PARTS OF THE MACHINE

- The position of the following individual working parts on the machine can be adjusted
 - Position and depth of the track cultivators
 - Height and down pressure of the front leveller
 - Depth of the shares
 - Position of the leveller behind the shares (only for sweeps)
 - Angle of the rear finishing levelling bar
- The control of the front leveller position and the share depth setting can be either mechanical, or automatic from the driver's position.
- The drawbars of folding can also be adjusted.

6.1 ADJUSTING THE POSITION AND DEPTH OF THE TRACK

CULTIVATORS

- The tractor track cultivator position can be adjusted either by height or length, as needed.
- When adjusting the track cultivator position, always observe generally valid labour safety regulations.
- Correct position of the track cultivator affects the resulting quality of processing.
- The track cultivators are located on the beams of the pulling fork. The drawbar beam for attaching track cultivators is telescopic.

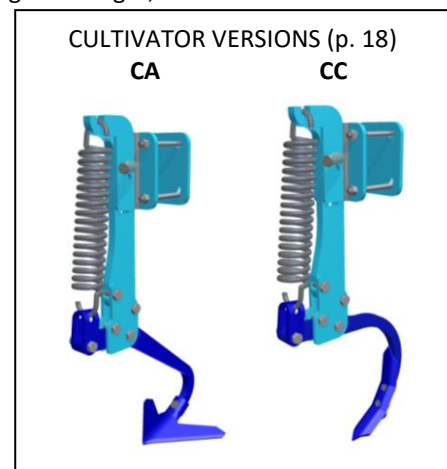
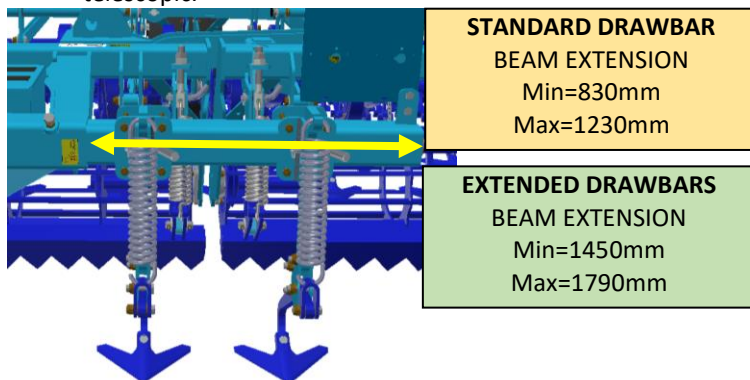

- The cultivator can be moved on the beam so that it loosens the compacted tractor wheel tracks. Lengthwise setting of the cultivators is performed by releasing the nuts of the screws and moving the cultivators along the beam into the position behind the tractor wheels so that they loosen the compacted tractor tracks.

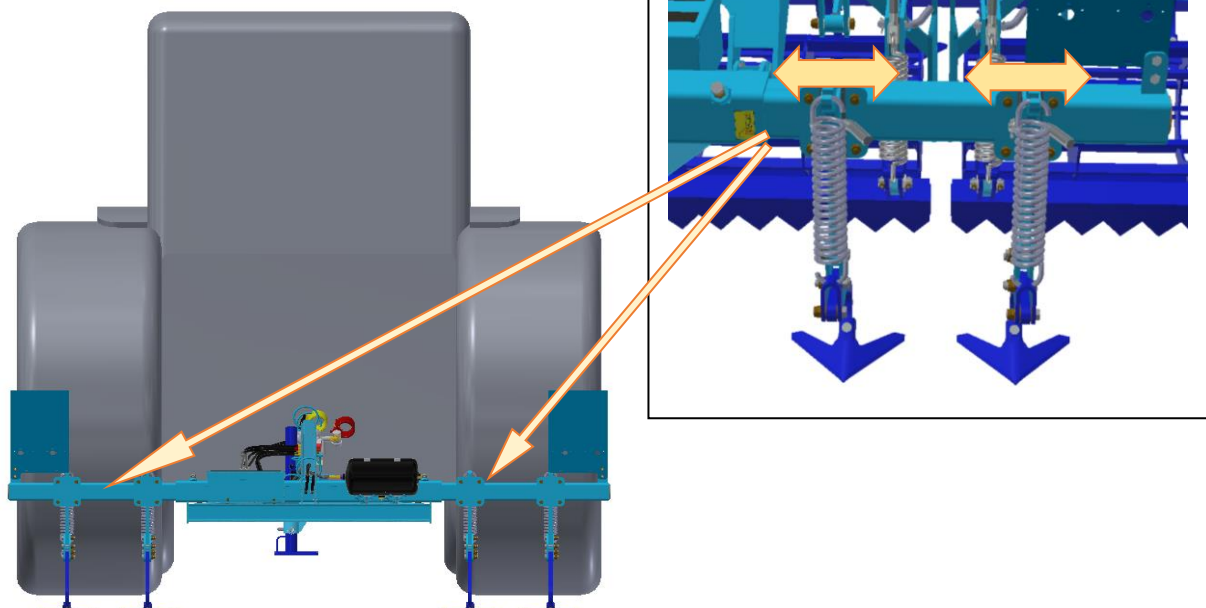

- Setting the depth of the cultivator is performed by removing the pin and moving the cultivator in the holder. Before setting the depth of the cultivators, set the machine in the position when the cultivators are not loaded.

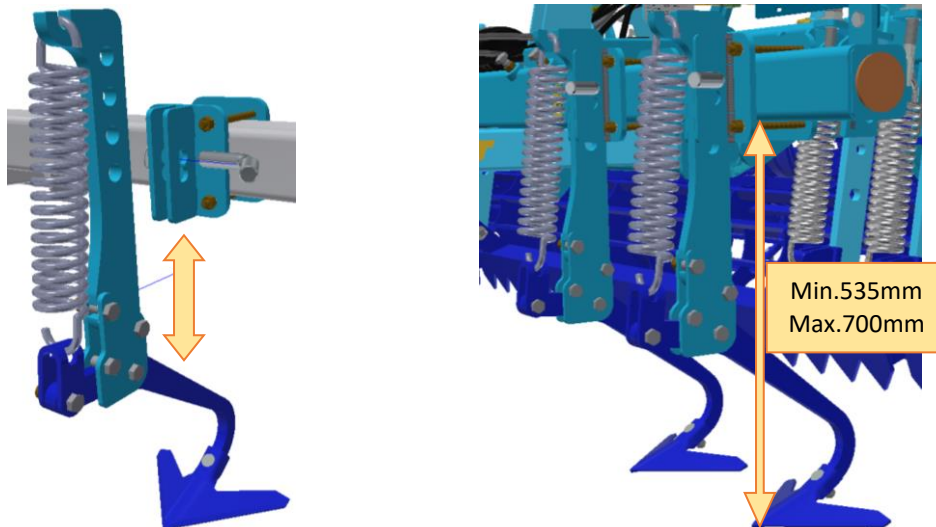

- The machines are standardly equipped with 2+2 cultivators = CA4 / CC4. A larger number can be used above standard, however, the maximum number is 4+4 = CA8 / CC8.

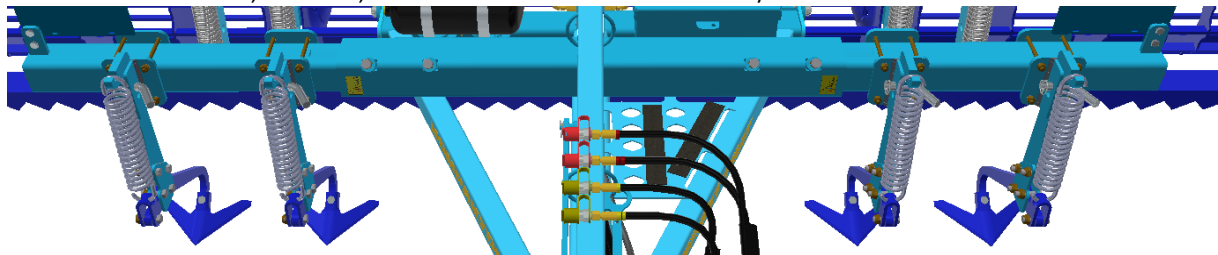

6.2 ADJUSTING THE SPRING-MOUNTED FRONT LEVELLER

- Correct position of the front leveller affects the resulting quality of processing.
- When adjusting the position of the levellers, always observe generally valid labour safety regulations.
- Perform the adjustment of front levellers when the machine is unfolded in the working position and standing on the working sections at the same time.
- The front leveller is a very important part of the machine. It contributes largely to the levelling ability of the Kompaktomat machines. Therefore, it is important to adjust it properly.

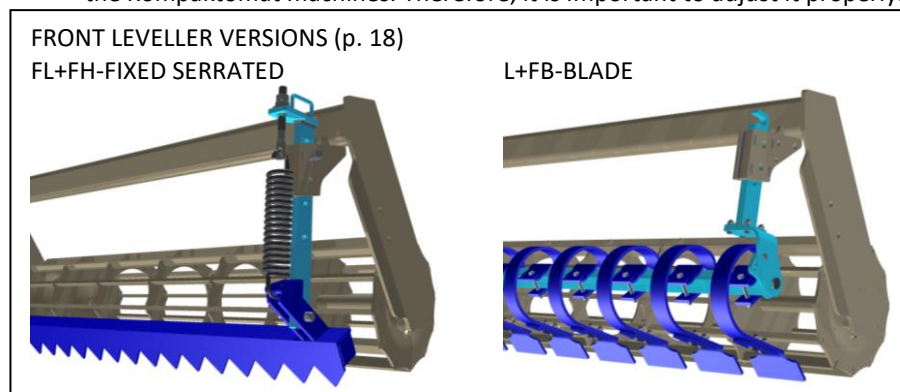

- As for the fixed serrated leveller, it is possible to adjust the height and the preloading of the draw spring.
- As for the blade leveller, it is possible to adjust the height and the angle of the blades.
- The basic version of the height adjustment is mechanical.
- It is possible to control the height of the leveller from the tractor cabin using a hydraulic circuit as an above-standard option.
 - The distribution of the hydraulic circuit includes elements providing even movement of all levelling bars. Therefore, do not limit the oil flow on the control panel of the circuit. The flow rate values should range between 75 and 100% capacity.
 - Without the manufacturer's prior consent, do not interfere with the hydraulic circuit components in any way!

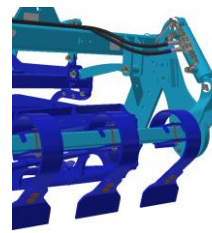
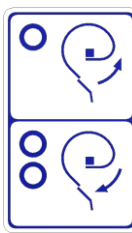

- The height of the front leveller is set in relation to the size of the clods and the field unevenness. The height of the leveller has to be adjusted according to the current conditions. When the leveller is too low, it will drag too much soil along, which reduces the tractor output. When the leveller is too high, it will not work, which will affect the final quality of work of the machine. We recommend to keep the leveller approx. 3cm above the surface when the machine is lowered down to the working rollers.

6.2.1 FL + FH – Front Fixed Serrated Levelling Bar

- The automatic release of the leveller is protected by a draw spring. The spring is factory-set to the length of 340mm; however, it is possible to change the preloading as needed. The spring preloading is selected according to the character of the field (size of clods in the field). The bigger the clods are, the higher the preloading needs to be.

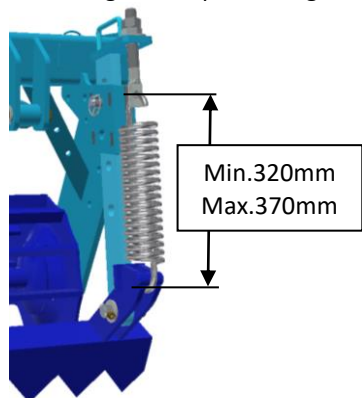

- Use an auxiliary control lever to make the manual leveller height setting easier.

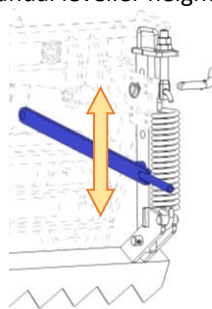
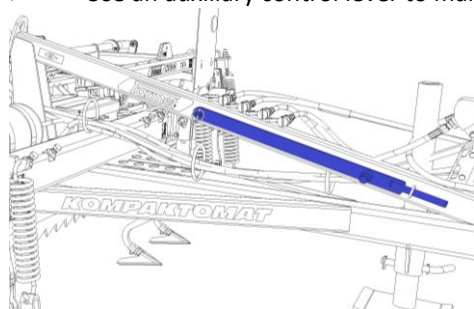

6.2.2 L + FB – Front Levelling Paddle Bar with Flexible Segments

- The automatic release of the leveller segments is secured by a flat spring of each segment.
- The height and angle of the blades can be adjusted by turning the leveller, manually or hydraulically.

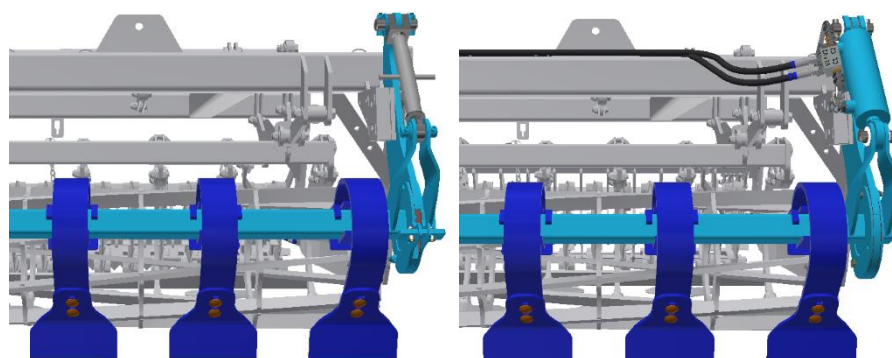

6.3 ADJUSTING THE COMPONENTS OF WORKING ROLLERS

- The design of the special roller versions require adjustment in order to provide quality soil processing.
- Always adjust the rollers when the machine is in standstill and observe generally valid labour safety regulations.

6.3.1 RR- RING ROLLERS

- To keep the quality of soil processing, the position of the digital deflectors against the ring roller must be adjusted.
- Adjusting the position of deflectors can be highly individual. It depends on the soil and climatic conditions.

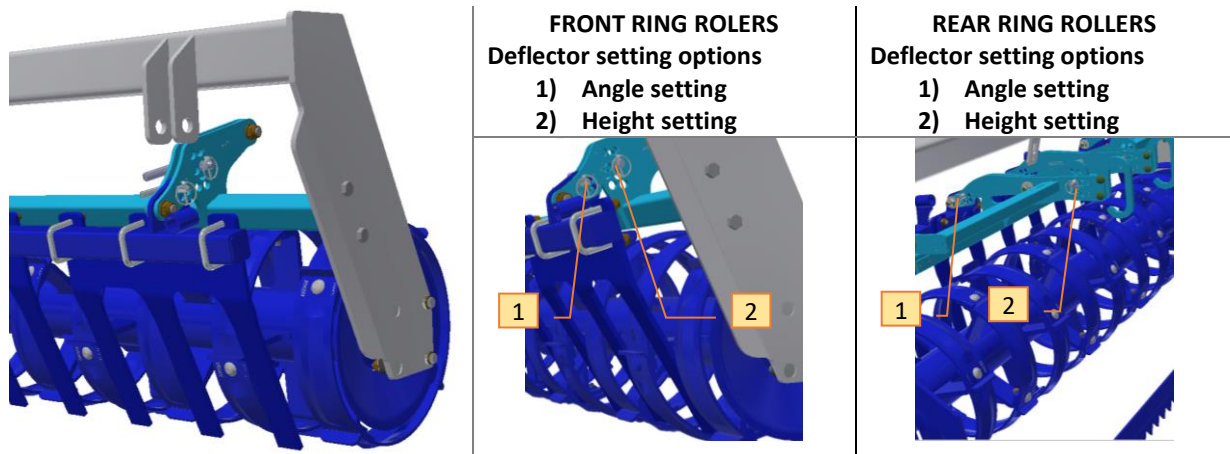

6.4 ADJUSTING THE DEPTH OF THE SHARE SECTION



- When adjusting the depth of the shares, always exercise extra caution as the working roller might turn.
- Always adjust the depth of the shares when the machine is in standstill and unfolded into the working position.
- The machine must be lifted on the axle and in the arms of the tractor so that it does not stand on the shares.
- The working depth of the shares is set in relation to the crop to be planted.
 - Beetroot...2-3 cm
 - Rapeseed ...3-5 cm
 - Wheat, barley, oats ...5-8 cm

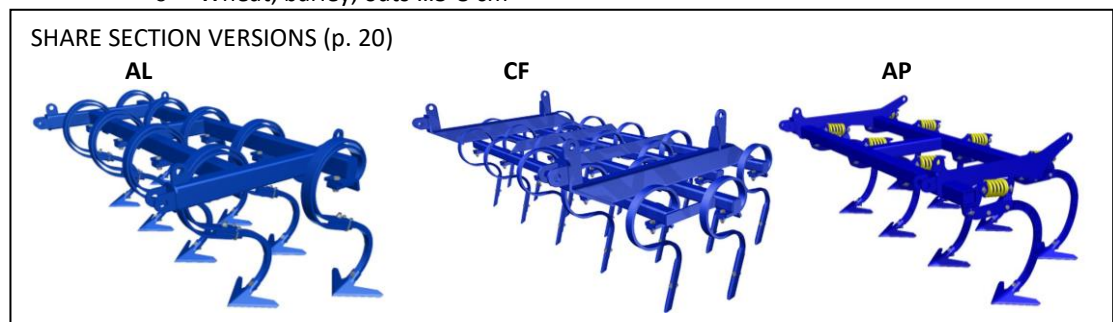

Machine	Number section (pc)
K500PS, K600PS, K700PS, K800PS	3
K1000PS	5

- The basic version of height setting is mechanical using a handle ...MCD

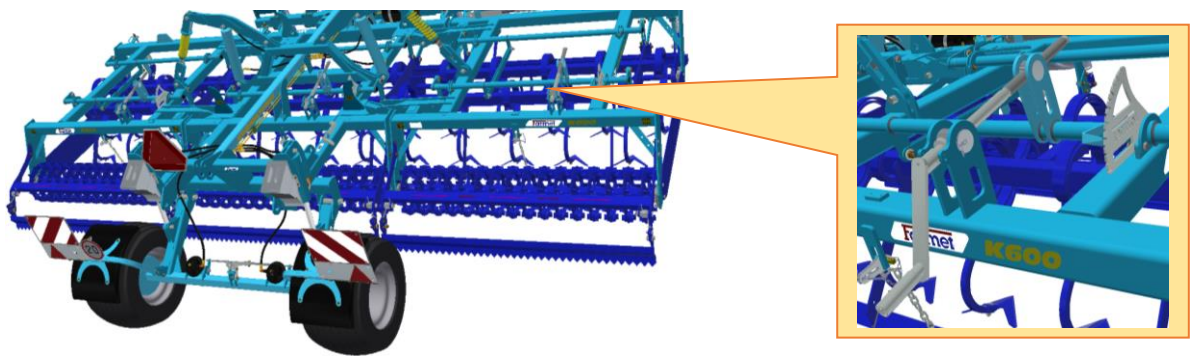

- The height of the shares can be controlled from the tractor cabin using a hydraulic circuit as an above-standard option ...**HD**
 - The distribution of the hydraulic circuit includes elements providing even movement of all share frames. Therefore, do not limit the oil flow on the control panel of the circuit. The flow rate values should range between 75 and 100% capacity.
 - Without the manufacturer’s prior consent, do not interfere with the hydraulic circuit components in any way!

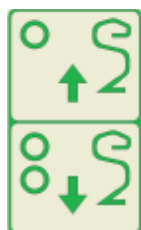

6.4.1 MCD- MECHANICAL DEPTH SETTING

- Standardly, the depth is set mechanically by turning the handle manually. Each working section of the machine is controlled individually.
- The depth setting is increased by turning the handle **anticlockwise** – **red arrows** in the picture.
- The depth setting is decreased by turning the handle **clockwise** – **white arrows** in the picture.
- There is an indicator near the handle that shows that all the sections are set at the same depth.

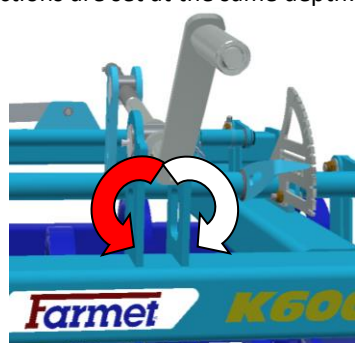
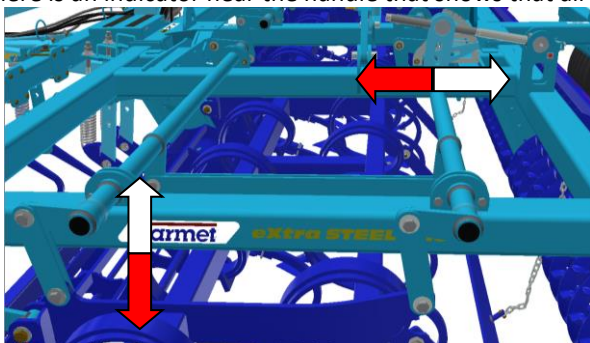

6.4.2 HD- HYDRAULIC DEPTH SETTING

- The depth is set from the tractor driver’s position. All working sections are controlled at the same time.
- The depth setting increases when the piston-rods are drawn out – **red arrows** in the picture.
- The depth setting decreases when the piston-rods are drawn in – **white arrows** in the picture.
- There are indicators located in spots visible from the tractor that show that all the sections are set at the same depth.

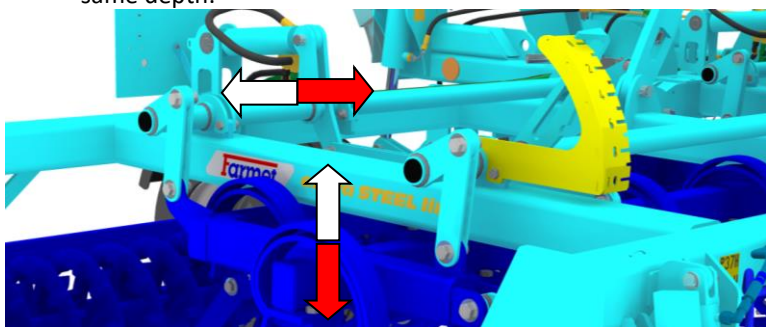

6.5 ADJUSTING THE LEVELLER HEIGHT BEHIND SHARES

- Perform the adjustment of the levellers when the machine is unfolded in the working position and standing still.
- The machine must rest on the working sections.
- When adjusting the position of the levellers, always observe generally valid labour safety regulations.
 - The leveller behind the shares is used for even spreading of the loosened soil behind the last row of sweeps in front of the rear roller.
 - Set the height of the leveller "V" according to the current soil conditions.
 - Correct position of the leveller affects the resulting quality of processing.
 - The correctly set leveller ensures that no tracks after the last row of shares are visible.
 - The position of the leveller is secured by inserting a chain loop into the hole on the supporting frame. The chain is secured by inserting a companion part and a safety pin.

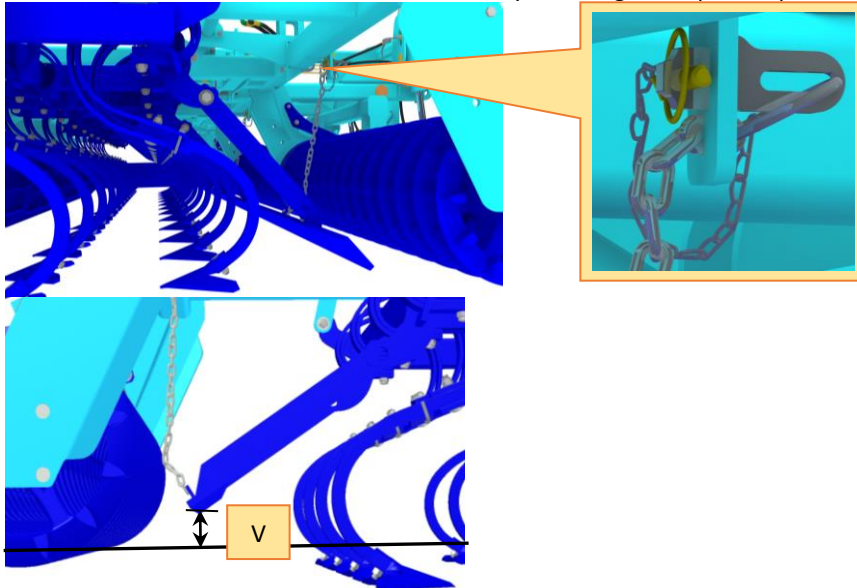

6.6 SETTING THE FINISHING SECTION FEATURES

6.6.1 SETTING THE ANGLE OF THE REAR LEVELLER

- When installing the leveller stops, always observe generally valid labour safety regulations.
- Correct function of the leveller affects the resulting quality of processing.

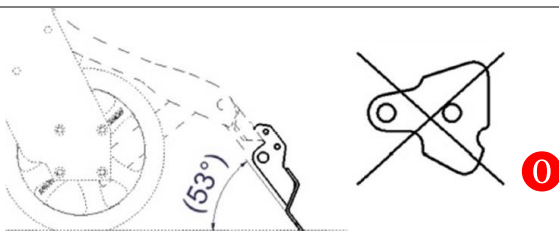

The angle of the finishing bar does not have to be changed in lighter soils or in deep cultivation when Kompaktomat creates enough loosened soil. **It means that the backstops do not need to be used 0.**

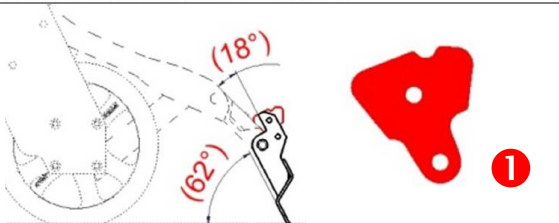

In heavier soils or shallow cultivation when Kompaktomat does not create enough loosened soil, it is possible to install backstops onto the rear leveller that increase the aggressiveness of its angle, thus assuring that the rear leveller generates a larger quantity of soil, improving the work of Kompaktomat.

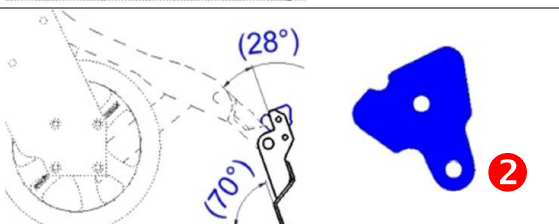

The backstop of the leveller is rotary but not symmetrical, thanks to which it is possible to create two angles of the leveller by turning the backstop.

1 Smaller preloading... red rotation of the backstop.

2 Greater preloading... blue rotation of the backstop.

There is a differentiating groove on the backstop for easier recognition during installation.

6.6.2 SETTING THE PRESSURE OF THE FINISHING ROLLER

- When adjusting the pressure, always observe work safety rules.
- The pressure mechanism of the finishing roller allows you to adjust the traction of the traction spring in three positions.
- To change the traction, use the level provided which you fix to the spring seating segment and shift along the rack with a swaying movement.

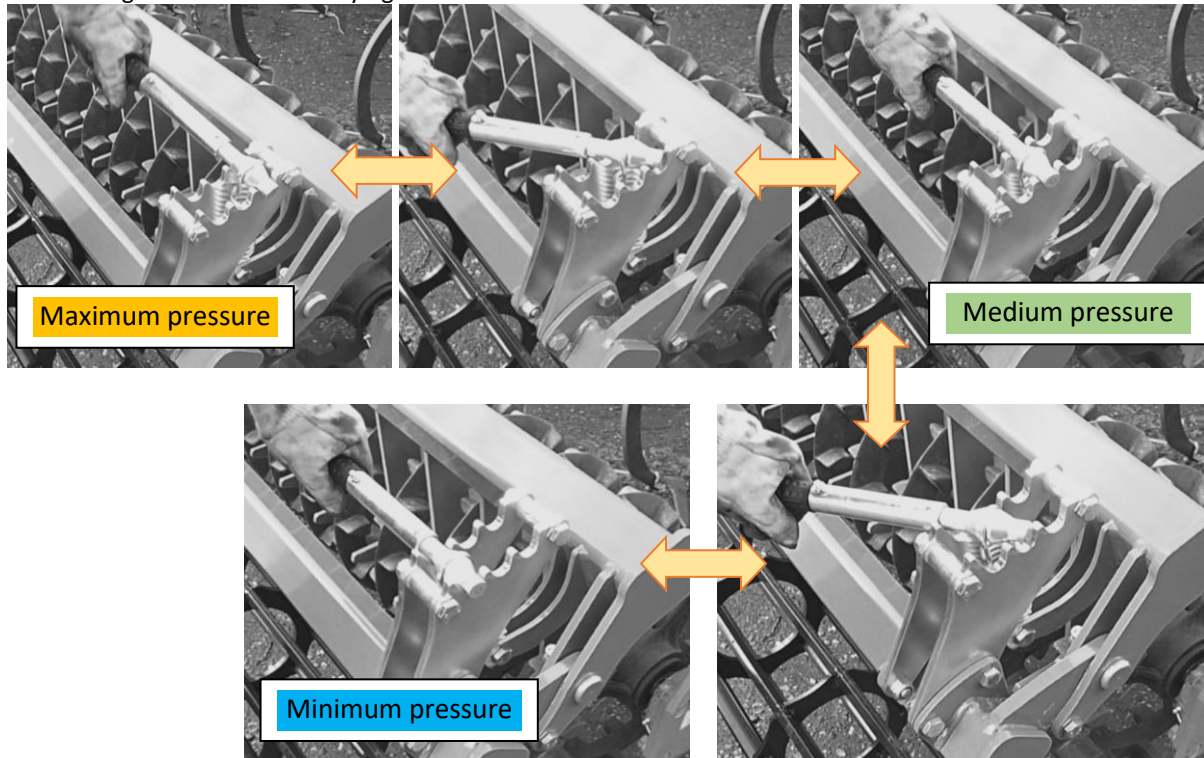

7. SIDE FRAME FOLDING DRAWBARS

- The folding mechanism of side frames connected to the central frame uses drawbars with integrated compression springs, thanks to which it is possible to achieve the partial transfer of the weight of the central frame onto the side frames, thus achieving even soil cultivation, when the central frame does not work deeper than the side frames.
- As soil conditions may differ, it is possible to change the spring preloading on the drawbars, or the entire length of the bar. The length of the bar needs to be considered when the machine is delivered disassembled and the length of the rod may change during shipping when compared with the factory settings.

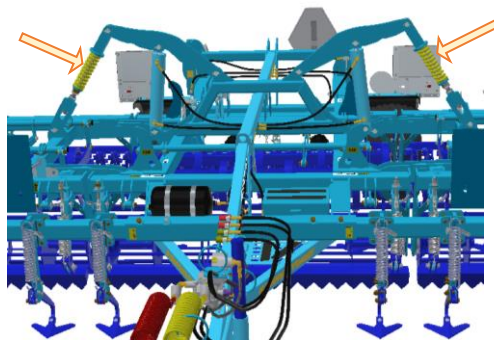

7.1 ADJUSTING THE FOLDING DRAWBAR SPRING -LP

- Always adjust the length of the spring when the machine is in standstill and unfolded in the working position.
- When adjusting, always observe generally valid labour safety regulations.
- When to change the spring preloading? When the folding piston-rod is completely drawn in during field work and the side frames are lifted and create a "V" shape. That means that the drawbar spring is not preloaded enough and it has to be preloaded more = shorten.

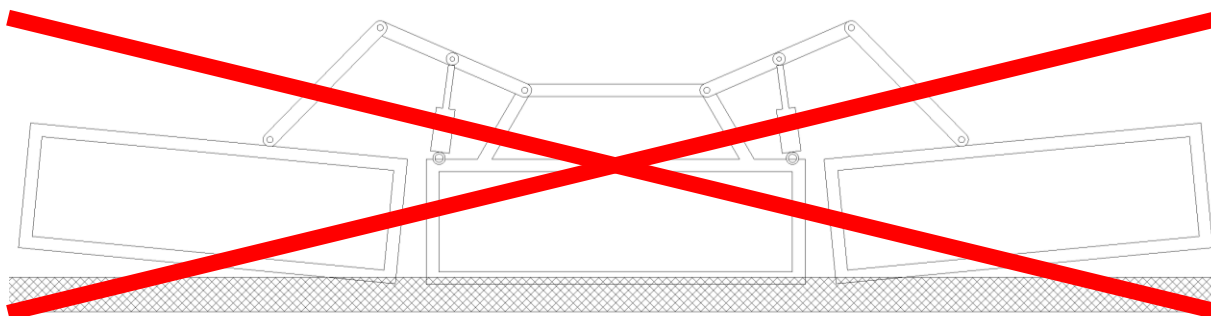
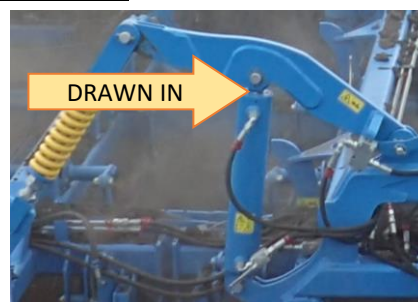

- The springs are factory-set to the L_p spring length. The spring preloading can be changed according to the current needs.

Machine type	L_p (mm)	Number (pcs)
K500PS	290	2
K600PS	280	2
K700PS	275	2
K800PS	265	2
K1000PS	280	4

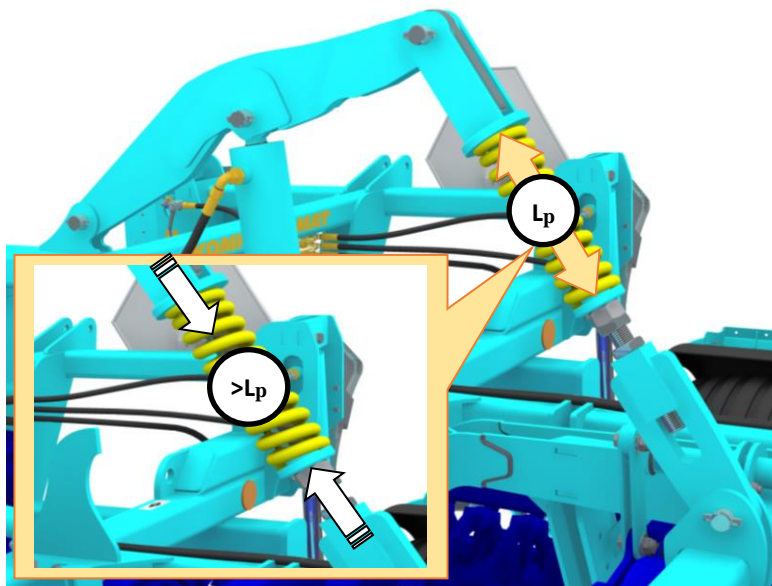

- By shortening the L_p spring length, the force of the spring is increased and the effect of the unloading of the central frame is greater. The permissible **spring preloading** against the standard dimension is **maximally -15mm**.

7.2 ADJUSTING THE LENGTH OF THE DRAWBAR -LT

- Always adjust the length of the drawbar when the machine is in standstill and unfolded in the working position.
- When adjusting, always observe generally valid labour safety regulations.
- Recommendations when to change the length of the drawbar L_t :

7.2.1 SHORTENING THE DRAWBAR

- The piston-rod is maximally drawn out when the side frames have been folded but the side frames are not resting on the stops of the central frame. There is a risk of damage to the frame structure during transportation.

7.2.2 EXTENDING THE DRAWBAR

- The piston-rod is not maximally drawn out when the side frames have been folded into the transport position but the side frames are already resting on the stops of the central frame. There is a risk of damage of the frame structure due to forces caused by the hydraulics.

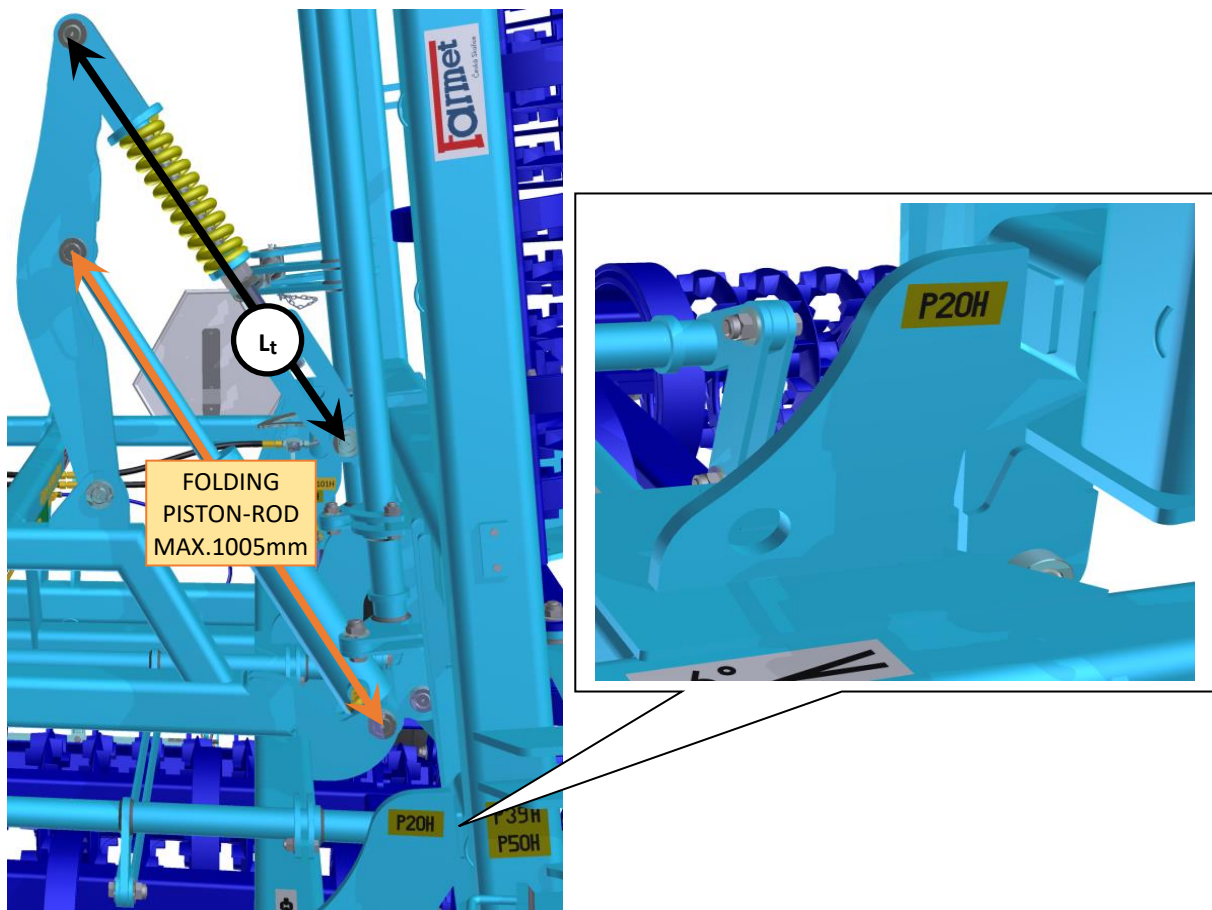

- Proceed as follows. Unfold the machine into the working position, ① changing the pin of the drawbar joint to the side frame, ② lift off the drawbar from the side frame, ③ turn the nut of the drawbar. When you change the length, proceed in the reverse way.

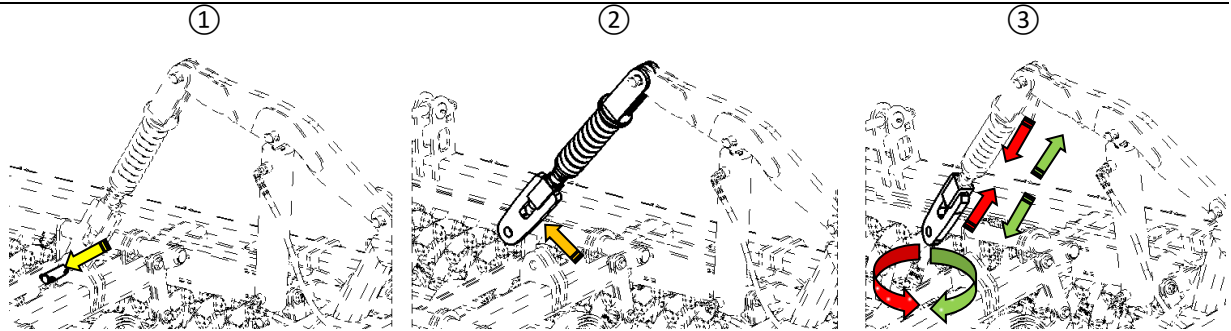

8 AGGREGATION WITH OTHER EQUIPMENT

- Semi-carried Kompaktomat machines can be optionally equipped with a rear three-point hitch TPH for aggregation with other equipment. Other equipment means carried equipment, such as crumbling rollers with cross-kill wheels, pneumatic drill machine or mechanical drill machine.
- **Only equipment that allows continuous tracing of the terrain can be aggregated with Kompaktomat. It is not possible to aggregate, for example, a drill machine without travelling wheels.**
- Only machines with the same working coverage as the Kompaktomat can be aggregated.
- When aggregating Kompaktomat and additional machine, always observe safety regulations and exercise increased caution.
- Perform aggregation on a flat and reinforced surface. Aggregation requires the assistance of another trained worker who will help you.
- It is only allowed to enter the area between the Kompaktomat and additional machine when both machines are in standstill.
- The aggregated machine changes the load on the Kompaktomat axle and the properties of driving, therefore exercise increased caution when driving with the set of Kompaktomat and aggregated machine.
- When driving such a set, always observe valid road traffic regulations.
- When working with the set of TRACTOR ⇒ KOMPAKTOMAT ⇒ OTHER EQUIPMENT, always observe the labour safety rules for working with Kompaktomat and another machine as well as the rules of safe road transportation.



K1000PS with DV1000 crumbling rollers



K600PS with Monsun ME600 drill machine



- When Kompaktomat is aggregated with another machine, the load of the Kompaktomat axle changes. Only additional machines that do not overload the transport axle of Kompaktomat can be aggregated. Follow the table below.

Maximum Permissible Weight of Another Machine for Aggregation with Kompaktomat					
	K500PS	K600PS	K700PS	K800PS	K1000PS
F _t (kg)	4025	4360	4960	5345	6920
F _n (kg)	5950		6800		
K1 (mm)	3895				3810
K2 (mm)	5750				5950
Centre of gravity	Maximum weight of equipment "M" (kg) at transport speed of 25 km/hour				
L= 1000 mm	2746	2553	2930	2708	2028
L= 1300 mm	2629	2444	2806	2593	1944
L= 1500 mm	2557	2377	2728	2522	1892
L= 1700 mm	2488	2313	2655	2454	1842
L= 2000 mm	2392	2223	2552	2359	1773

K1...dimension invariable no.1; K2...dimension invariable no.2;

F_t...weight of the machine in the centre of gravity; F_n...maximum permissible axle load

- The calculated value (weight) "M" will help you check the possibility of trouble-free aggregation of another machine with Kompaktomat.
- Formula for the calculation of the maximum permissible weight of additional equipment for aggregation with Kompaktomat:

$$M = \frac{(-F_t * K_1) + (F_n * K_2)}{L + K_2}$$

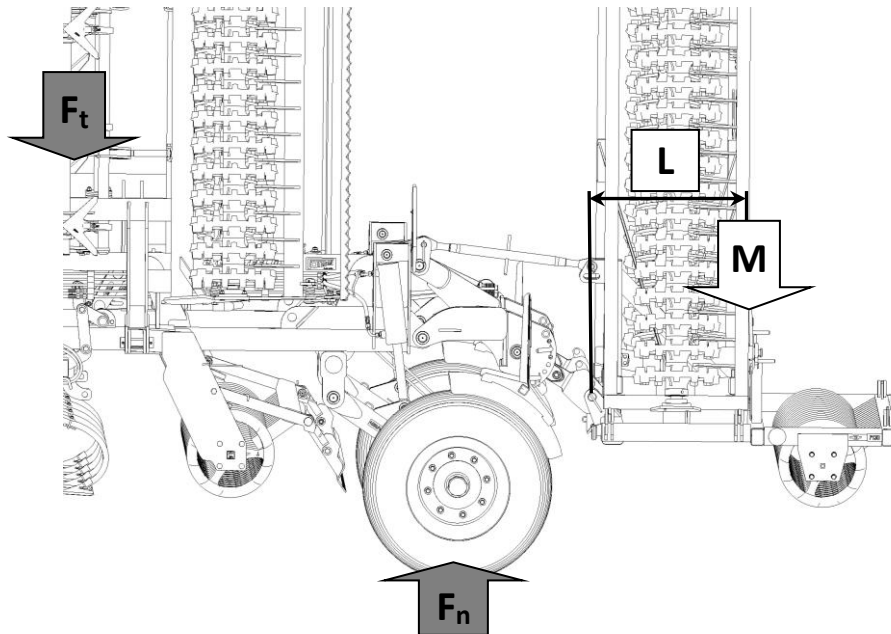

8.1 TRANSPORT POSITION OF THE KOMPAKTOMAT THREE-POINT

HITCH ARMS

- Before driving the set on roads, you have to secure the arms of the Kompaktomat hitch against movement upwards. Secure them using the support pins.

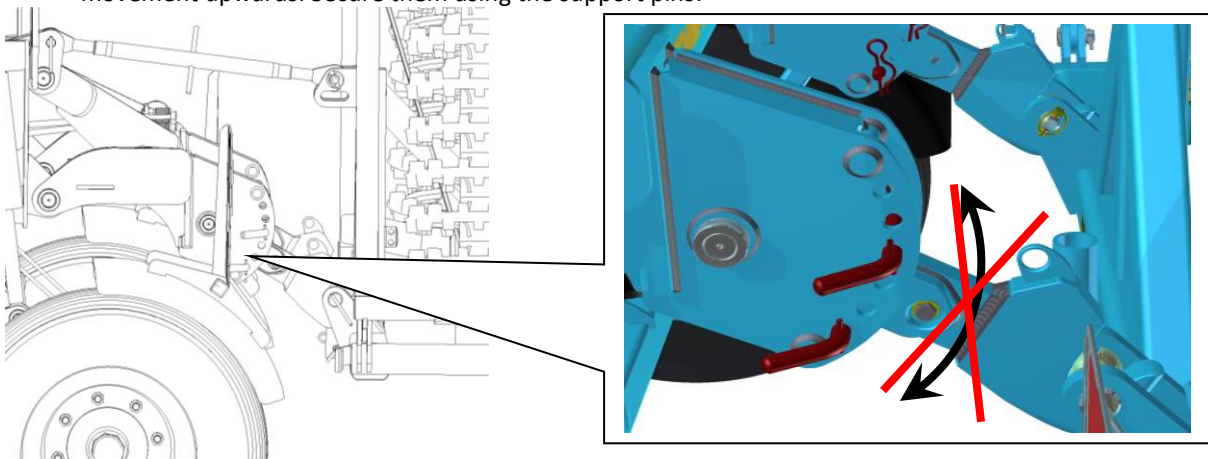

8.2 WORKING POSITION OF THE KOMPAKTOMAT THREE-POINT HITCH

ARMS

- The arms must be allowed to swivel in order to let the equipment aggregated to Kompaktomat freely trace the terrain.
- This is done as follows:

1. Moving support pins to the edge holes of the brackets.

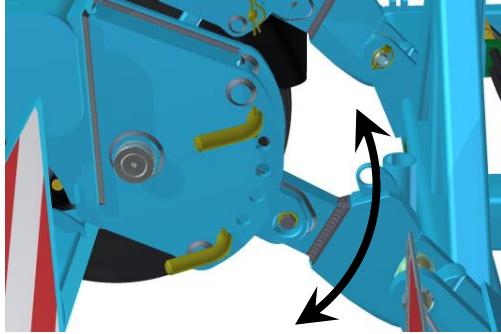

2. Completely removing support pins.

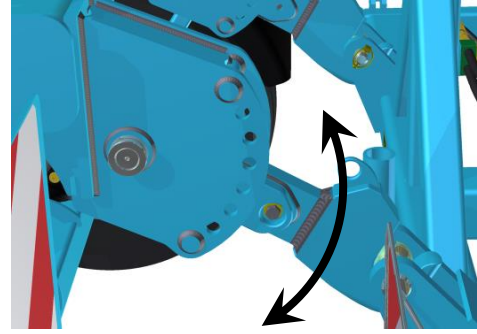

- Moving or removing support pins allows free terrain tracing of the machine aggregated to Kompaktomat. At the same time, the rear roller of Kompaktomat will not be overloaded in the working position.
- Failure to observe this adjustment will damage the structure and rear roller of Kompaktomat, for which the Manufacturer shall not be liable.



8.3 AGGREGATION WITH PNEUMATIC DRILL MACHINE

- Pneumatic drill machines that have a fan driven by a fluid motor, not a drive shaft, may be aggregated with Kompaktomat.
- To aggregate Kompaktomat and the pneumatic drill machine with a fluid fan motor, Kompaktomat can be optionally equipped with a hydraulic circuit for the fan drive.

8.3.1 FAN DRIVE CIRCUIT HC

- A set of hydraulic components providing the transport of hydraulic oil from the tractor to the drill machine.
- The requirement regarding the connection of the hydraulic hose Dn 20- ISO20 directly into the tractor oil tank, and not through the distributor, must be observed to ensure trouble-free function of the circuit and the seed drill fan drive.

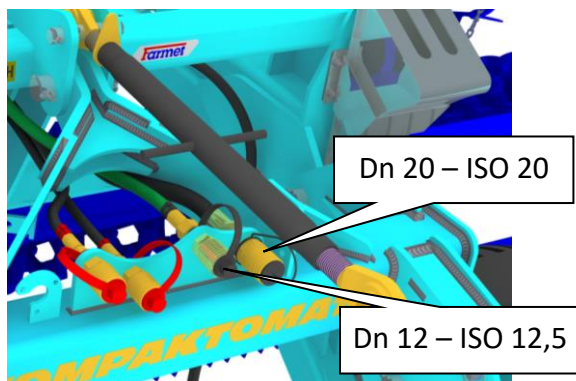

8.3.2 CIRCUIT FOR CONTROLLING MARKERS BM

- A set of hydraulic components providing the transport of hydraulic oil from the tractor to the drill machine.
- As the seed drills have various marker control systems, it is possible to use hydraulic circuits for marker control in Kompaktomat.
- These circuits can also be used with mechanical seed drills in Kompaktomat.
 - Single-line circuit



- Double-line circuit

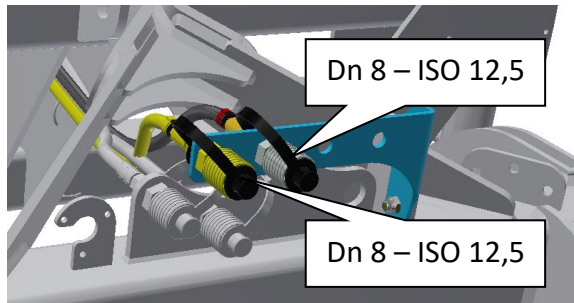

8.4 BRAKE AIR PRESSURE VALUE SETTING

- When Kompaktomat is aggregated with another machine, the Kompaktomat axle load changes! Therefore, it is necessary to set the correct brake circuit pressure value for the axle. This achieves the proper function of the brake system of the machine set.
- When setting the brake circuit pressure, adhere to all safety rules and regulations.

8.4.1 WEIGHING THE AXLE LOAD OF THE SET

Prior to setting the pressure value, the set must be weighed to determine the current axle load of Kompaktomat.



8.4.2 KOMPAKTOMAT AXLE BRAKE CIRCUIT PRESSURE SETTING

- You must know the current Kompaktomat axle load.
- The pressure value is set by turning the knob on the pressure regulator installed near the air tank on the drawbar.

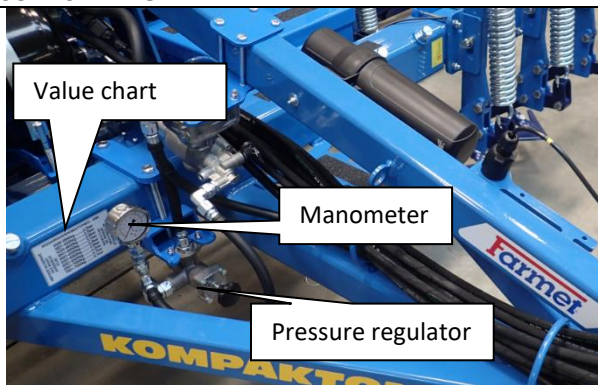

- Near the manometer, there is a chart where you will find the measured weight to be used for setting the correct pressure value in the brake circuit by turning the knob.

*Example:
If the measured weight of the set with the Kompaktomat axle load is between 5001 and 5500kg, set the pressure at 3.5 bar.*

PRESSURE VALUES FOR K500-K600PS

BRZDA/BRAKE/BREMSE/TOPMO3 - 306E	
HMOTNOST NA NÁPRAVĚ AXLE WEIGHT ACHSGEWICHT ОСЬ БЕС	3500-3850kg.....3,6bar 3851-4200kg.....3,3bar 4205-4600kg.....2,9bar 4601-5000kg.....2,6bar
NASTAVTE TLAK SET PRESSURE DRUCK EINSTELLEN УСТАНОВИТЕ ДАВЛЕНИЕ	

PRESSURE VALUES FOR K700-K1000PS

BRZDA/BRAKE/BREMSE/TOPMO3 - 309E	
HMOTNOST NA NÁPRAVĚ AXLE WEIGHT ACHSGEWICHT ОСЬ БЕС	3500-3850kg.....5,1bar 3851-4200kg.....4,7bar 4205-4600kg.....4,3bar 4601-5000kg.....3,9bar 5001-5500kg.....3,5bar 5501-6000kg.....3,1bar 6001-6500kg.....2,8bar 6501-7000kg.....2,5bar 7001-7500kg.....2,2bar
NASTAVTE TLAK SET PRESSURE DRUCK EINSTELLEN УСТАНОВИТЕ ДАВЛЕНИЕ	



- When you disconnect the auxiliary equipment from Kompaktomat, the Kompaktomat axle load must be weighed again and the correct pressure for the machine must be set!

All the aforesaid steps require the set to be aggregated with a tractor that has a functional brake linkage. The tractor motor must be running to supply pressure to the brake circuit.



9 MAINTENANCE AND REPAIRS OF THE MACHINE

- Observe the safety instructions and regulations for maintenance and repairs.
- Check that all screws and other assembly points are tight before each use of the machine and whenever needed.
- Regularly check the prescribed pressure in tyres of the machine and the condition of the tyres.
- Regularly check the wear and tear of the working parts of the machine. The quality of work decreases with the worn working parts.
- Lubricate all indicated lubrication places according to Chapter 9.1.
- Replace shares according to Chapter 9.2.
- Adjusting, cleaning and lubricating the machine may only be performed when the machine is standing still, i.e. the machine is stopped and is not working.
- When adjusting, cleaning, maintaining and repairing the machine, secure the folding and rotary parts of the machine that could put the operator in danger by fall or other movement.
- When repairing the unfolded machine parts, use a suitable support device leaning against labelled places or appropriate places.
- For attaching the machine when manipulating it with the use of lifting equipment, use only places marked by stick-on labels with the symbol of a chain .
- If there is a defect or damage on the machine, immediately turn off the tractor engine and secure the engine from turning on, secure the set and the machine against movement ⇒ then you can remove the defect.
- When repairing the machine, use only original spare parts, suitable tools and protective equipment.
- Order original spare parts according to the Spare Parts Catalogue.
- If you have to weld during the repair and have the machine attached to the tractor at the same time, the supply cables have.



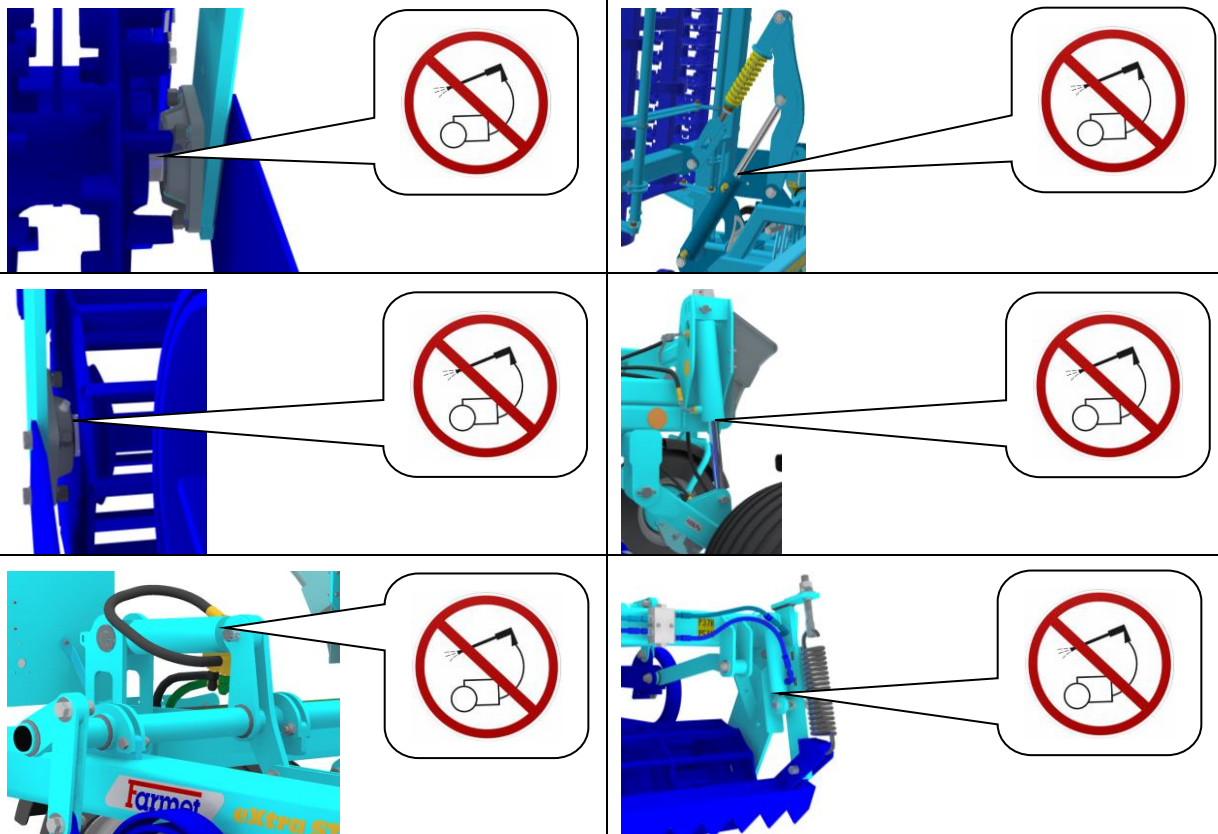

We do not recommend cleaning the hydraulic piston-rods and bearings of working rollers by high-pressure wash or by washing with direct water stream.

The sealing of the piston-rods and bearings of the rollers might get damaged during high-pressure wash or direct stream of water.



MAINTENANCE PLAN

Perform the planned maintenance according to the instructions:

Maintenance Task	Daily (season)	Once a week	Before season	After season	Time interval
Machine in general					
<ul style="list-style-type: none"> • Visual inspection of the machine • Checking for any undesirable sounds, vibrations and excessive wear 	X				
<ul style="list-style-type: none"> • Checking crucial nodes: pins, bearings, rollers, working parts 	X		X	X	
<ul style="list-style-type: none"> • Machine cleaning • Storing the machine under roof, if possible • Recording the mileage of the machine/season (ha) 		X		X	
<ul style="list-style-type: none"> • Comprehensive inspection • Checking the frame 	X			X	
<div style="display: flex; align-items: center;">  <p>Do not use a high-pressure cleaner or direct stream of water to clean the hydraulic rollers, bearings, electric and electronic parts. The seals and bearings are not waterproof at high pressure.</p> </div>					
Hydraulic system					
Checking the function, tightness, mounting and worn spots of all hydraulic parts and hoses		X	X		
Hydraulic hoses – replacement: <ul style="list-style-type: none"> • Damaged external casing of the hose (mechanically or blistered) • Fluid seepage (especially the end piece) • Bumps or blisters on the hose • Deformed or corroded end piece • Loose end piece – the hose spins 	X			X	
Hydraulic hoses - replacement: <ul style="list-style-type: none"> • Expired service life of the hose <div style="display: flex; justify-content: space-around; margin-top: 5px;">   </div>					6 years
!!! PREVENTION means removing the problem according to the plan, outside the season, without stress and comfortably before a secondary problem, an accident or a health hazard arises.					

MAINTENANCE PLAN

Perform the planned maintenance according to the instructions:

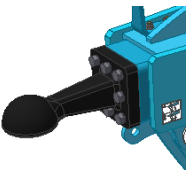
Maintenance Task	Daily (season)	Once a week	Before season	After season	Time interval						
Bolt connections											
Visual inspection of bolt and hydraulic joints, tighten any loose joints using a corresponding torque (see the torque chart)	X			X							
Towing lug – check, tighten if needed <table border="1" style="margin-left: 20px; margin-top: 10px;"> <tr> <td>M16 - 10.9.</td> <td>300 Nm</td> </tr> <tr> <td>M20 - 10.9.</td> <td>560 Nm</td> </tr> </table> 	M16 - 10.9.	300 Nm	M20 - 10.9.	560 Nm		X	X				
M16 - 10.9.	300 Nm										
M20 - 10.9.	560 Nm										
Wheels – tighten all wheel nuts. <ul style="list-style-type: none"> • First time: after 10 hours of operation • Wheel replacement: after 10 hours of operation <table border="1" style="margin-left: 20px; margin-top: 10px;"> <tr> <td>M 18 x 1.5</td> <td>300 Nm</td> </tr> <tr> <td>M 20 x 1.5</td> <td>400 Nm</td> </tr> <tr> <td>M 22 x 1.5</td> <td>500 Nm</td> </tr> </table>	M 18 x 1.5	300 Nm	M 20 x 1.5	400 Nm	M 22 x 1.5	500 Nm		X	X		
M 18 x 1.5	300 Nm										
M 20 x 1.5	400 Nm										
M 22 x 1.5	500 Nm										
Brake system											
Brake line and hoses – check the function, tightness, mounting and clamping, or breaking	X		X	X							
Brake components – check the function, tightness, mounting	X		X	X							
Air nozzle – drain using the draining valve		X		X							
Draining valve – check the function, clean and replace sealing			X	X							
Pipe filter – clean			X	X							
Brake/parking brake – check the function, escapement setting 25-45mm	X										
Brake lining – check the condition of the brake lining, min. thickness of 3mm				X							
Wheels/axle											
Checking the tyre pressure											
Transport axle K500-1000PS	19.0/45-17 144 A8 pressure 350 kPa	X			X						
	19.0/45-17 148 A8 pressure 330 kPa										
	19.0/45-17 152 A8 pressure 390 kPa										
	19.0/45-17 157 A8 pressure 475 kPa										
	500/50-17 149 A8 pressure 300 kPa										
	500/50-17 154 A8 pressure 300 kPa										
	500/50-17 155 A8 pressure 300 kPa										
Transport axle bearings – check and adjust allowance if needed (in the workshop)				X							

MAINTENANCE PLAN

Perform the planned maintenance according to the instructions:

Maintenance Task	Daily (season)	Once a week	Before season	After season	Time interval
Electric cables					
Check for any damage, replace if needed		X	X		
Safety measures					
Lighting and safety hatched boards – check the condition, function and cleanliness	X		X		
Hazard and safety labels – check that they are installed and legible		X			
Machine lubrication plan					
Drawbar joint / lifting loop – grease	X			X	
Handbrake bolt – grease or suitable oil	X			X	
Axle bearings – grease with Lithium content – check, refill if needed				X	
After season					
Entire machine					
<ul style="list-style-type: none"> • Treat and clean the machine; do not spray oil or similar agents on the plastic parts • Spray the piston-rods of the hydraulic cylinders with suitable anti-corrosion agents • Check the tightness of all bolt and plug-in connections (see the torque chart) • Check for any damage of the electric cables and replace if needed 					
Brake system					
<ul style="list-style-type: none"> • Preserve the anti-freeze fluid for air-brake systems (about 0.1l), ethanol-free, before the last ride, use fluid recommended by the tractor manufacturer. • Secure the machine against movement by Scotch blocks. • Release the parking brake, release air from the air nozzle and close the brake lines. The service brake must be released during winter so that it does not get stuck on the brake drum 					
Points of lubrication					
Grease the points of lubrication according to the lubrication plan, use grease KP2P-20 Likx , under DIN 51 502					
!!! PREVENTION means removing the problem according to the plan, outside the season, without stress and comfortably before a secondary problem, an accident or a health hazard arises.					

9.1 LUBRICATION PLAN FOR THE MACHINE

Regular lubrication of lubricating places increases the usable life of the nodes and the machine. Perform lubrication according to the "Lubrication Plan".

When lubricating the bearings of the rollers, observe caution so that you do not damage the bearings. When lubricating the bearings of the rollers, turn the roller around so that the lubricant spreads evenly.

Lubricate the nodes until clean lubricant is coming out of them. Then wipe the lubricant off.

Places and intervals of lubrication

PLACE FOR LUBRICATION	INTERVAL	LUBRICANT
Controlling handle	-Always before work with the machine.	-Plastic lubricant according to DIN 51 502
Pole joint	Always after the work and before putting the machine out of operation.	1) K EP2 - 30 2) KP2P-20 Likx
Lubricating the controlling handle		Lubricating the pole joint

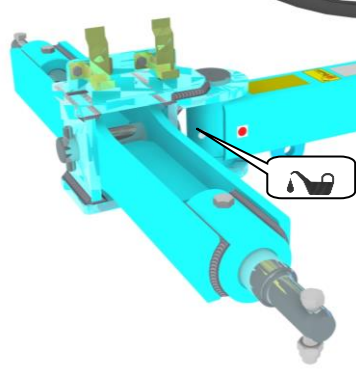
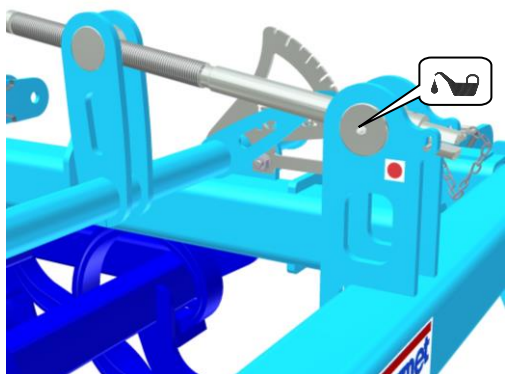

MANIPULATION WITH LUBRICANTS:



- Treat oils and lubricants as hazardous waste according to valid regulations and acts.
- Protect yourself from direct contact with oils by using gloves or protective lotion.
- Wash oil stains on skin thoroughly with warm water and soap. Do not clean the skin with petrol, diesel oil or other dissolving agents.
- Oil or lubricant is poisonous. If you swallow any, immediately seek a doctor.
 - Keep oil and lubricants out of reach of children.



9.2 REPLACEMENT OF WORN SHARES

- Always observe the safety regulations and instructions when replacing shares.
- The machine must be aggregated with the tractor according to chapter 4.1/p.24 when shares are replaced. The tractor must be turned off and the operator or repairer must prevent free access of unauthorized persons to the tractor.
- Replace the shares on solid and even surface and when the machine is standing still.
- If the hydraulic system of the tractor is not tight, you have to provide mechanical supports for the machine pole.

9.2.1 REPLACEMENT OF WORN SHARES ON THE CENTRAL FRAME

- Only for combinatorators K500PS, K600PS, K700PS, K800PS, K1000PS.
- Place the machine into the transport position according to chapter 4.3.1/p.31.
- Lift the rear arms of the tractors TPH with the aggregated machine to the maximum position and secure it against falling. Then you can replace the worn shares.

Replacement of shares on the central frame

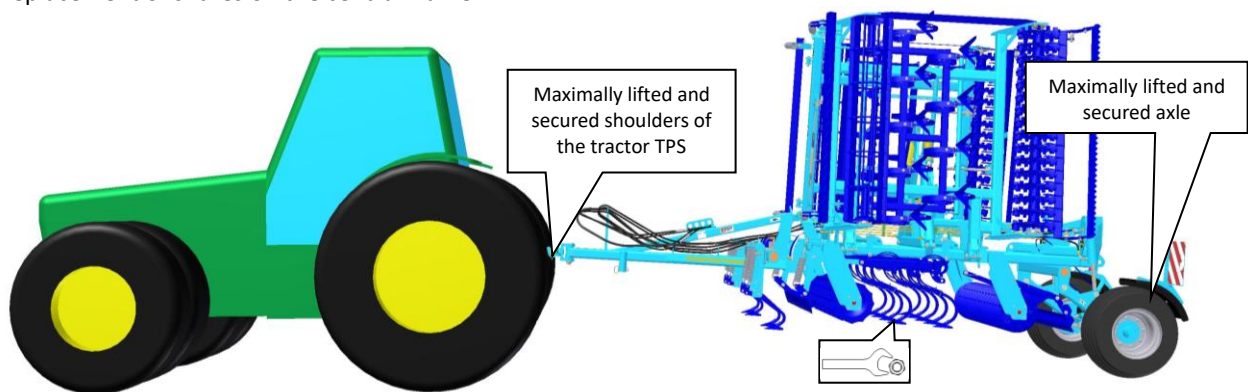

9.2.2 REPLACEMENT OF WORN SHARES OF THE SIDE FRAME

- Place the machine into the transport position according to chapter 4.3.1/p.31.
- Replace the shares you can reach.
- To replace shares you cannot reach, unfold the side frames into the position when they are almost in the working position. In this position secure the side frames by a mechanical support against unexpected fall.
- When the side frames are secured, you can start replacing the shares.

Replacement of shares on the side frames

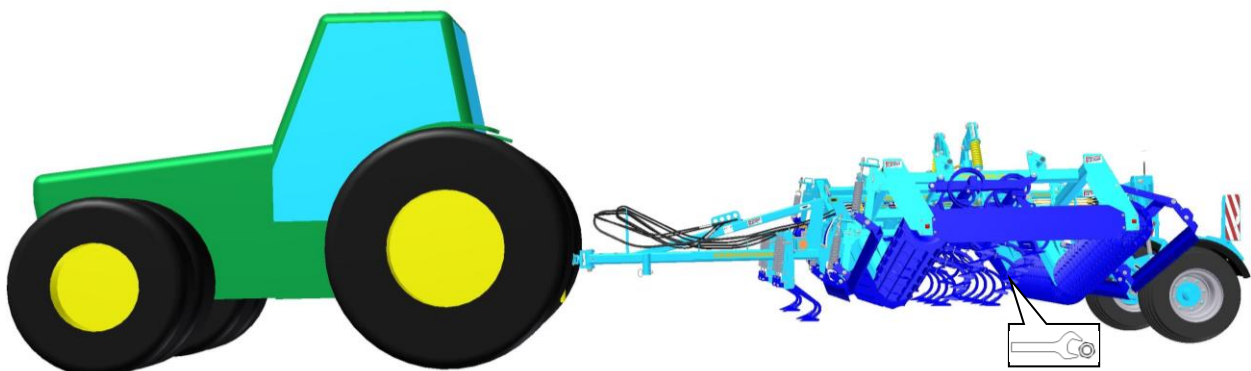

9.3 SPECIFICATION OF SPARE PARTS FOR AXLES

- To provide proper specification of spare parts, it is required to take a photo of the axle label and include the production number of the machine. It will make the proper specification of the spare part easier and faster.

9.4 REPLACEMENT OF THE WORKING ROLLER BEARINGS

- Always follow the safety regulations and directives when replacing the bearings of rollers.
- The machine must be aggregated with the tractor according to Chapter "4.1/p.24" when replacing the bearings. The tractor engine must be switched off for the replacement of bearings and the operator, or repairman, must prevent any access to unauthorised persons to the tractor.
- Only replace the roller bearings on a solid and flat ground and when the machine is in standstill.
- In the case of leaks in the tractor hydraulic system, you are required to provide mechanical supports under the machine drawbar.

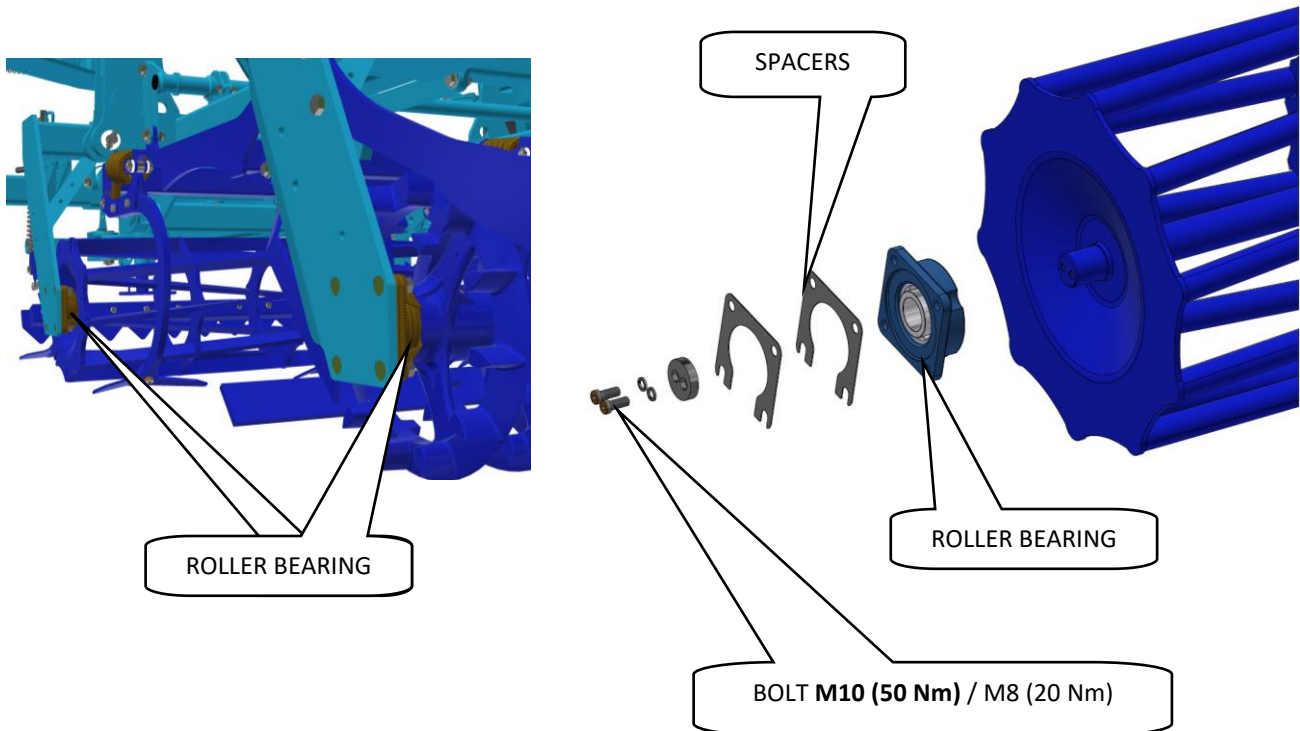

9.4.1 USING THE TOOL FOR BEARING DISASSEMBLY AND ASSEMBLY

➤ The tool placed in the box on the machine.

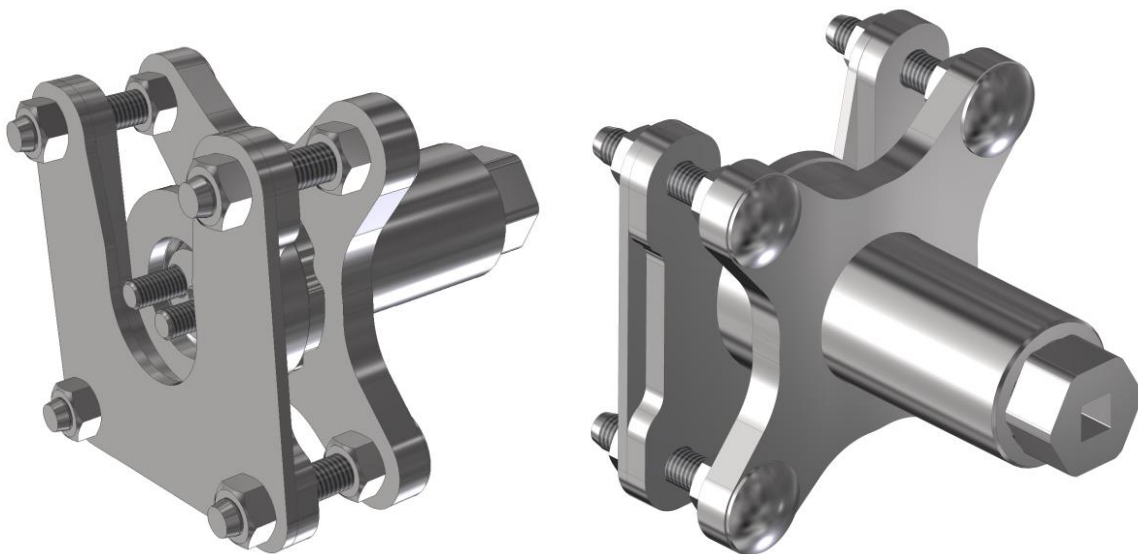

Tool parts:

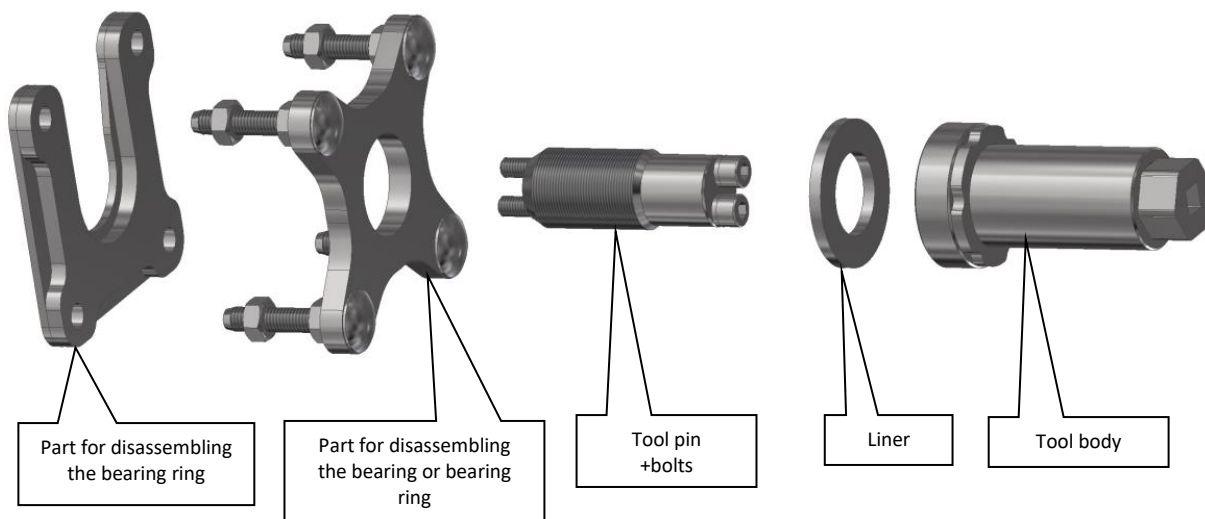

9.4.1.1 COMPLETE BEARING DISASSEMBLY

➤ Procedure:

- .1 Mount and screw the tool pin onto the cylinder pin.

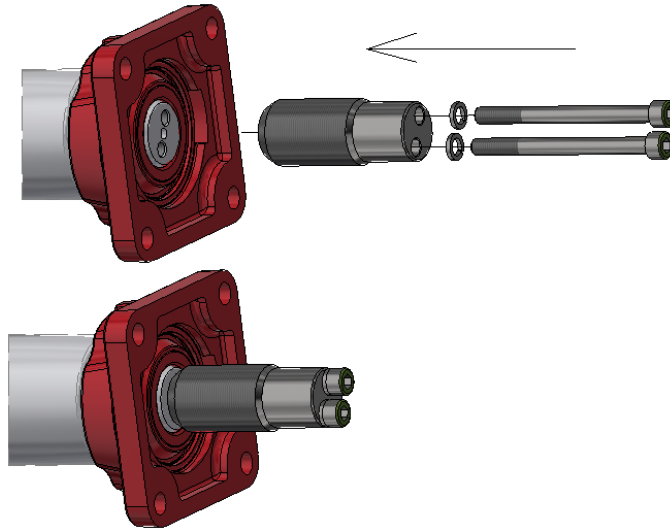

- .2 Screw the tool body in, insert the part for bearing disassembly and mount onto the bearing using the nuts.

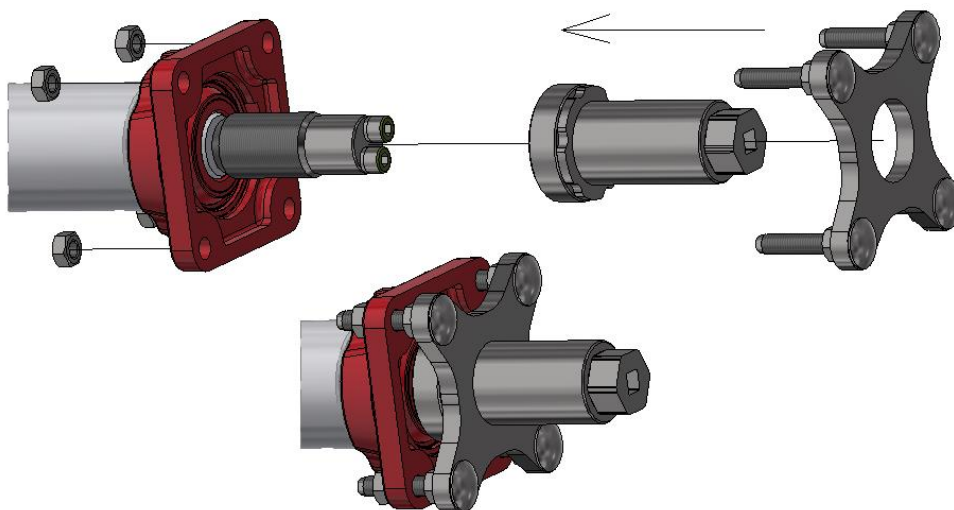

- .3 Disassemble the bearing by screwing the tool body using spanner size 36.

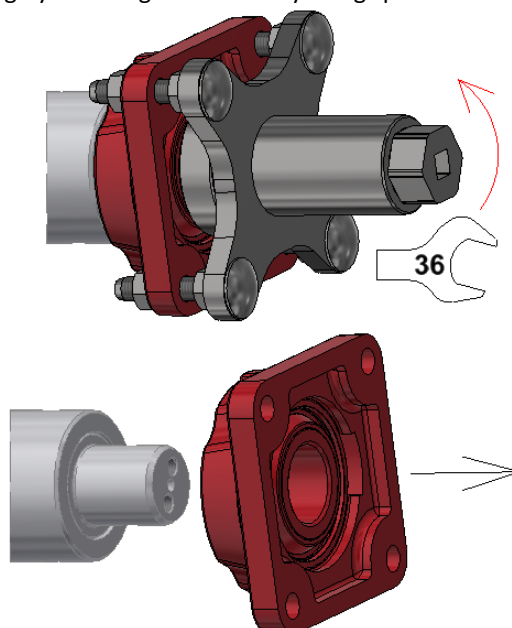

9.4.1.2 DISASSEMBLY OF THE RING

➤ Procedure:

- .1 Mount and screw the tool pin onto the cylinder pin.

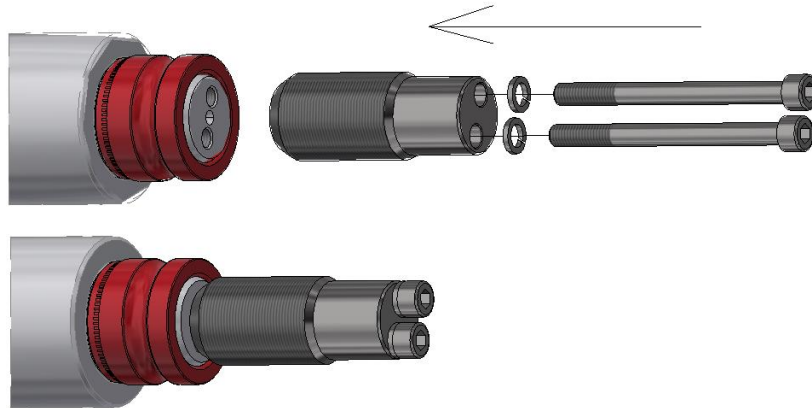

- .2 Screw the tool body, mount the part for disassembling the bearing, mount the part for disassembling the ring and attach it using the nuts.

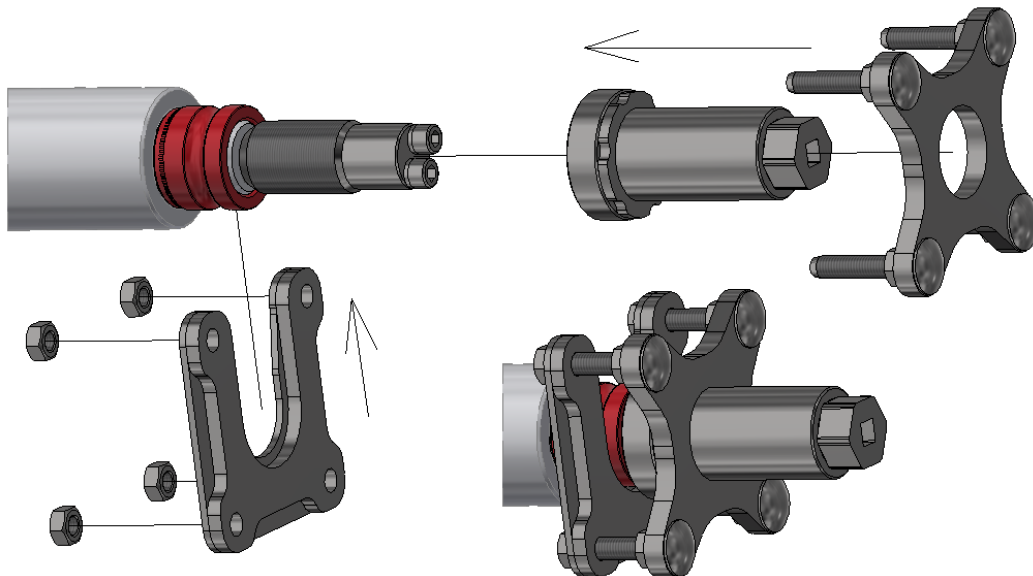

- .3 Disassemble the ring by screwing the tool body using spanner size 36.

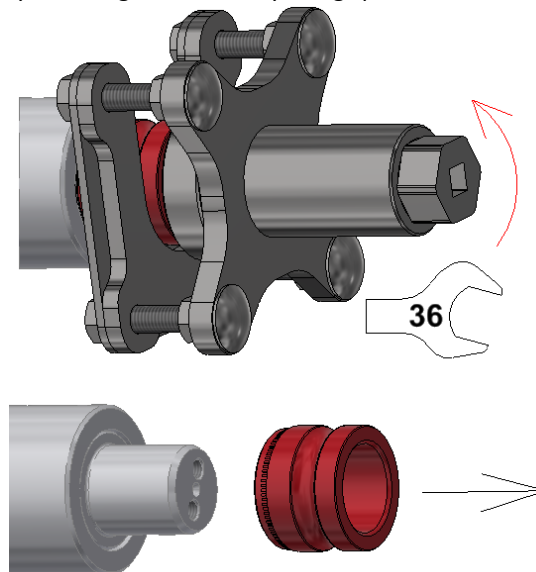

9.4.1.3 ASSEMBLING BEARINGS ONTO PINS

➤ Procedure:

- .1 Mount and screw the tool pin onto the cylinder pin.

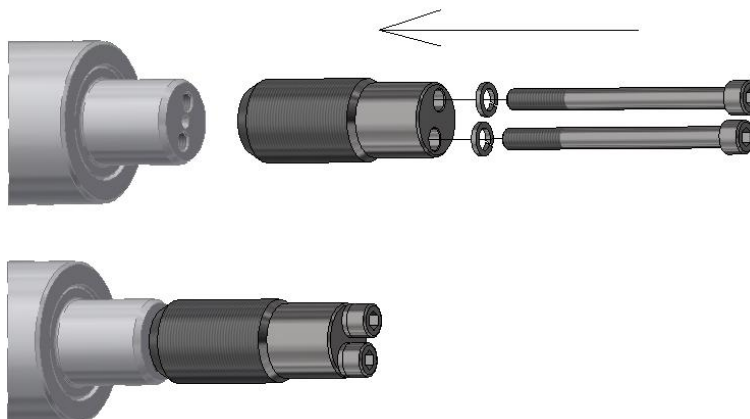

- .2 Mount the bearing + liner and screw the tool body in.

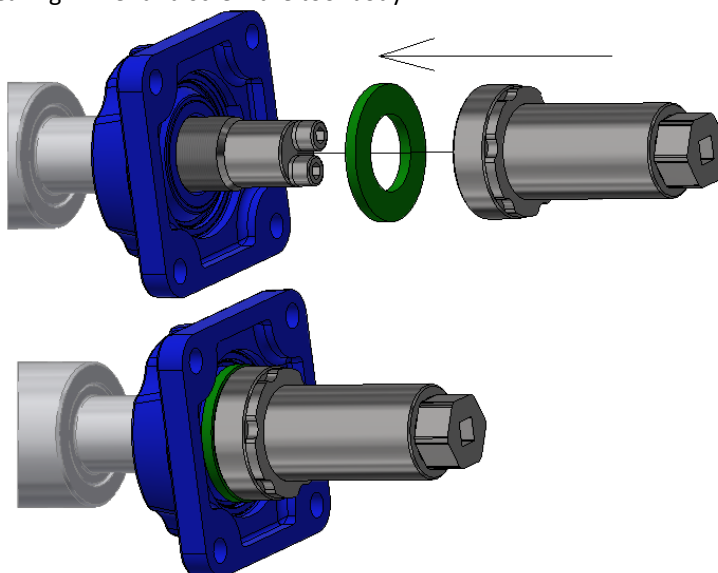

- .3 Assemble the bearing by screwing the tool body using spanner size 36.

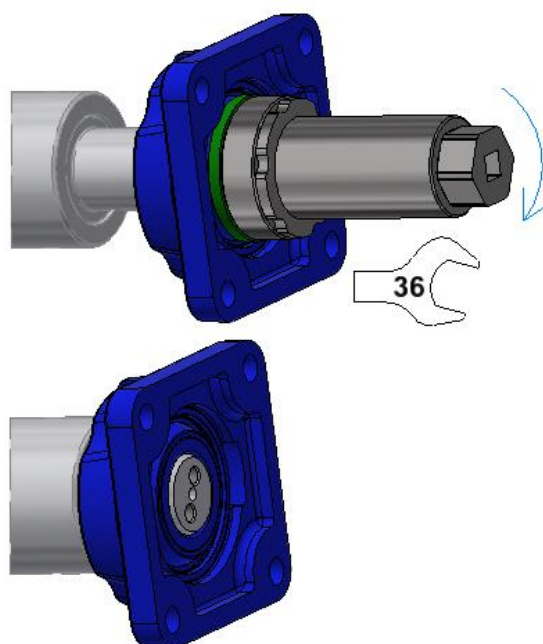

9.4.2 USING SPACER

- The spacers are used for defining production tolerances. Therefore, they do not have to be always used.
 - Mount the house bearings to the rollers
 - Insert the roller with the bearings between the frame side plates and assess whether you need to use the SPACERS

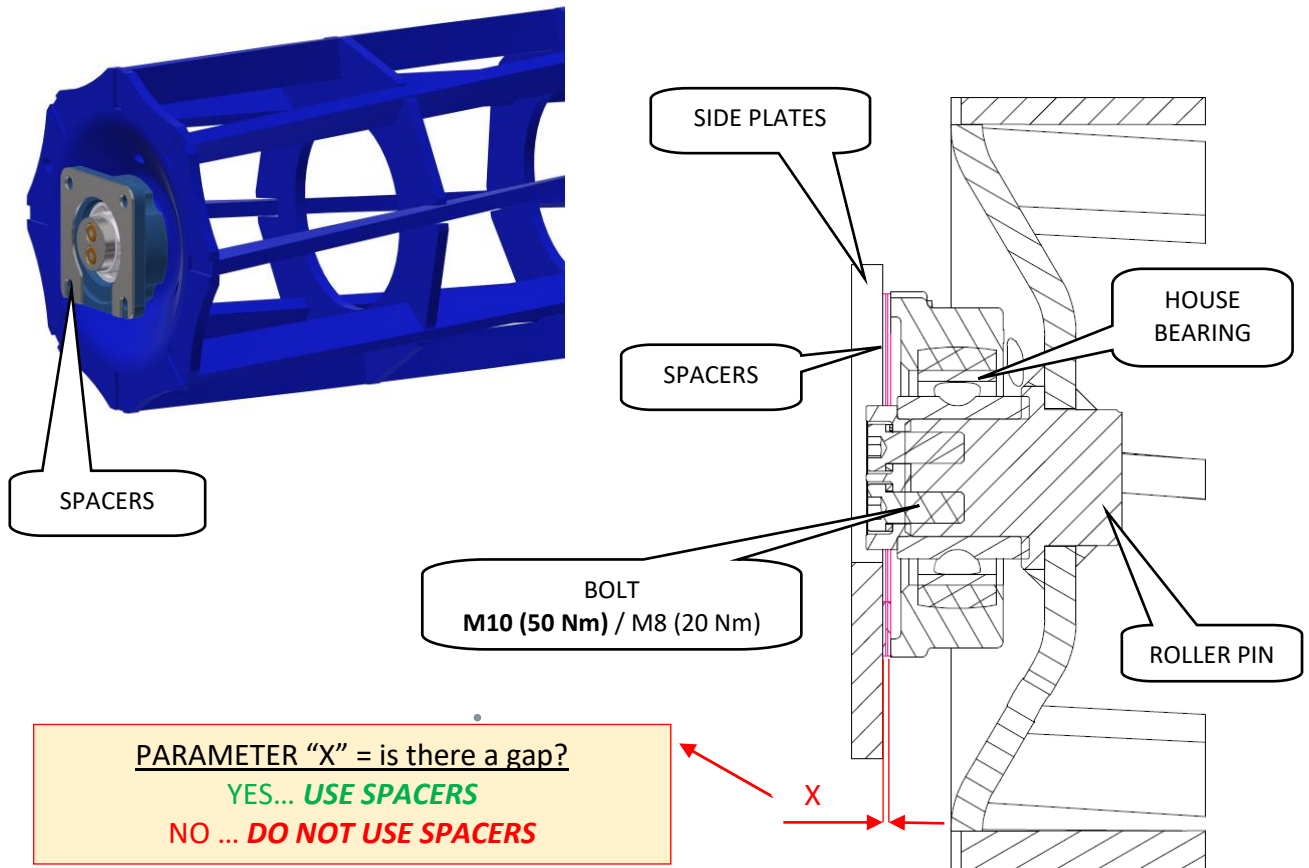

10 MACHINE STORAGE – LONG-TERM MACHINE SHUTDOWN:

- Store the machine under a roof, if possible.
- Store the machine on an even and solid ground with sufficient bearing capacity.
- Clean the machine before storing and make sure that the machine is not damaged during the storage. Pay special attention to all labelled lubricating places and lubricate the machine according to the lubrication plan.
- Store the machine with folded frames in the transport position. Leave the machine on the axle and the standing leg; secure the machine against movement with wedges or other suitable instruments.
- The machine must not be leaning on the shares as they may get damaged.
- Prevent access by unauthorized persons to the machine.
- Lower the axle of the machine into a lower position with the use of the hydraulic circuit; secure the piston-rods with ball valves.

Lowering the height of the machine on the axle when laying it off

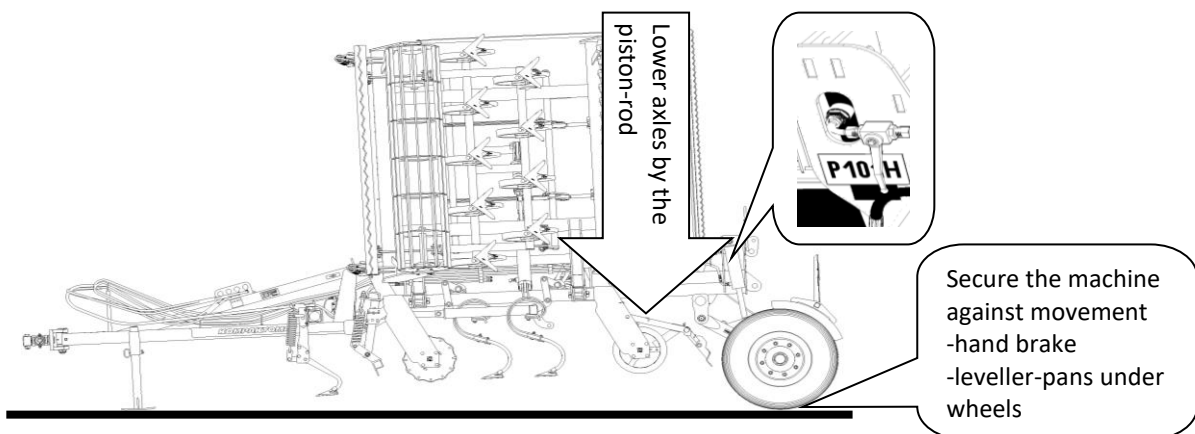

11 PROTECTION OF ENVIRONMENT

- Check the tightness of the hydraulic system regularly.
- Replace or repair hydraulic tubes or other parts of the hydraulic system showing signs of damage, before oil starts to leak.
- Check the condition of hydraulic tubes and execute their timely replacement. The usable life of hydraulic tubes also includes the storage time.
- Treat oils and lubricants according to valid acts and regulations on wastes.

12 MACHINE DISPOSAL AFTER SERVICE LIFE EXPIRY

- The operator must secure during machine disposal that steel parts and parts, in which hydraulic oil or lubricating grease moves are differentiated.
- Steel parts must be cut by the operator while observing safety regulations and handed over to the secondary raw material collection point. He must proceed with other parts according to valid laws about waste.

13 SERVICING AND WARRANTY CONDITIONS

13.1 SERVICING

Servicing is secured by the dealer after consulting with the manufacturer, possibly directly by the manufacturer. Spare parts then using the sales network by individual sellers in the entire country. Use only the spare parts according to the spare parts catalogue officially issued by the manufacturer.

13.2 WARRANTY

- 13.2.1 The manufacturer provides a warranty of 24 months for these machine parts: main frame, axle, and machine tow bar. For other parts of the machine, the manufacturer provides a warranty of 12 months. The warranty is provided from the date of sale of the new machine to the end user (consumer).
- 13.2.2 The warranty applies to hidden defects that will show in the warranty period with proper use of the machine and while fulfilling the conditions stated in the operating manual.
- 13.2.3 The warranty does not apply to wearable spare parts, i.e. regular mechanical wear and tear of replaceable parts of the working sections (shares, edges, etc.).
- 13.2.4 The warranty does not apply to indirect consequences of possible damage, such as service life decrease etc.
- 13.2.5 The warranty is bound to the machine and is not void upon an owner change.
- 13.2.6 The warranty is limited to the disassembly and assembly, possibly replacement or repair of the defective part. The decision, whether to replace or repair the defective part, is up to the contractual workshop of Farmet.
- 13.2.7 During the warranty period, only the authorised servicing technician of the manufacturer may perform repairs or other interventions into the machine. In the opposite case, the warranty will not be acknowledged. This provision does not apply to the replacement of wearable spare parts (see point 13.2.3).
- 13.2.8 The warranty is conditioned by using the genuine spare parts of the manufacturer.

(CZ) ES PROHLÁŠENÍ O SHODĚ
 (GB) CE CERTIFICATE OF CONFORMITY
 (D) EG-KONFORMITÄTSEKTLÄRUNG
 (F) DÉCLARATION CE DE CONFORMITÉ
 (RU) СЕРТИФИКАТ СООТВЕТСТВИЯ ЕС
 (PL) DEKLARACJA ZGODNOŚCI WE

1. (CZ) My (GB) We (D) Wir (F) Nous (RU) Мы (PL) My: **Farmet a.s.**
 Jiřínková 276
 552 03 Česká Skalice
 Czech Republic
 DIČ: CZ46504931
 Tel/Fax: 00420 491 450136

(CZ) Vydáváme na vlastní zodpovědnost toto prohlášení. (GB) Hereby issue, on our responsibility, this Certificate. (D) Geben in alleiniger Verantwortung folgende Erklärung ab. (F) Publiions sous notre propre responsabilité la déclaration suivante. (RU) Под свою ответственность выдаем настоящий сертификат. (PL) Wydajemy na własną odpowiedzialność niniejszą Deklarację Zgodności.

2. (CZ) Strojní zařízení: - název : **Polonesený sklápěný kompaktomat**
 (GB) Machine: - name : **Semi-Mounted unfolding Kompaktomat**
 (D) Fabrikat: - Bezeichnung : **Klappbare Aufsattelgeräte Kompaktomat**
 (F) Machinerie: - dénomination : **Compactomats de semi-portage basculants**
 (RU) Сельскохозяйственная машина: - наименование : **Полунавесной складной компактомат**
 (PL) Urządzenie maszynowe: - nazwa : **Półzawieszony opuszczany Kompaktomat**
- typ, type : **KOMPAKTOMAT-PS**
 - model, modèle : **K 400 | 450 | 500 | 600 | 700 | 800 | 1000 PS**
 - PIN/VIN :
- (CZ) výrobní číslo :
 - (GB) serial number
 - (D) Fabriknummer
 - (F) n° de production
 - (RU) заводской номер
 - (PL) numer produkcyjny:

3. (CZ) Příslušná nařízení vlády: č.176/2008 Sb. (směrnice 2006/42/ES). (GB) Applicable Governmental Decrees and Orders: No.176/2008 Sb. (Directive 2006/42/ES). (D) Einschlägige Regierungsverordnungen (NV): Nr.176/2008 Slg. (Richtlinie 2006/42/ES). (F) Décrets respectifs du gouvernement: n°.176/2008 du Code (directive 2006/42/CE). (RU) Соответствующие постановления правительства: № 176/2008 Сб. (инструкция 2006/42/ES). (PL) Odpowiednie rozporządzenia rządowe: nr 176/2008 Dz.U. (Dyrektywa 2006/42/WE).

4. (CZ) Normy s nimiž byla posouzena shoda: (GB) Standards used for consideration of conformity: (D) Das Produkt wurde gefertigt in Übereinstimmung mit folgenden Normen: (F) Normes avec lesquelles la conformité a été évaluée: (RU) Нормы, на основании которых производилась сертификация: (PL) Normy, według których została przeprowadzona ocena: ČSN EN ISO 12100, ČSN EN ISO 4254-1.

(CZ) Schválil (GB) Approve by date: 01.03.2022
 (D) Bewilligen (F) Approuvé
 (RU) Утвердил (PL) Uchwalili

V České Skalici dne: 01.03.2022

Ing. Petr Lukášek
 technický ředitel
 Technical director

Ing. Karel Žďárský
 generální ředitel společnosti
 General Manager

Farmet a.s.
 Jiřínková 276
 552 03 Česká Skalice
 DIČ CZ46504931
 59